

Platforms

Bridging the gap
between construction +
manufacturing

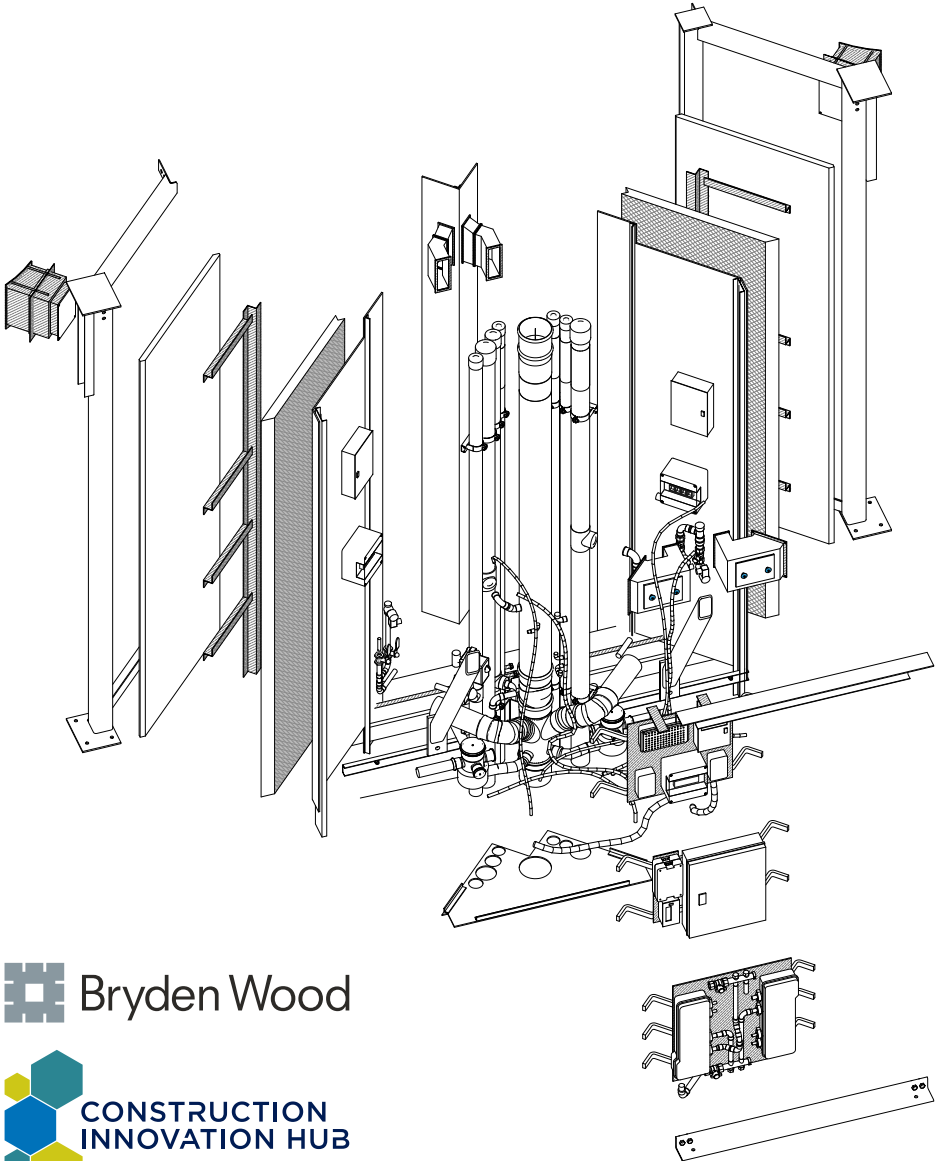

 Bryden Wood

 CONSTRUCTION
INNOVATION HUB

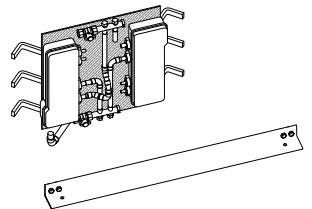

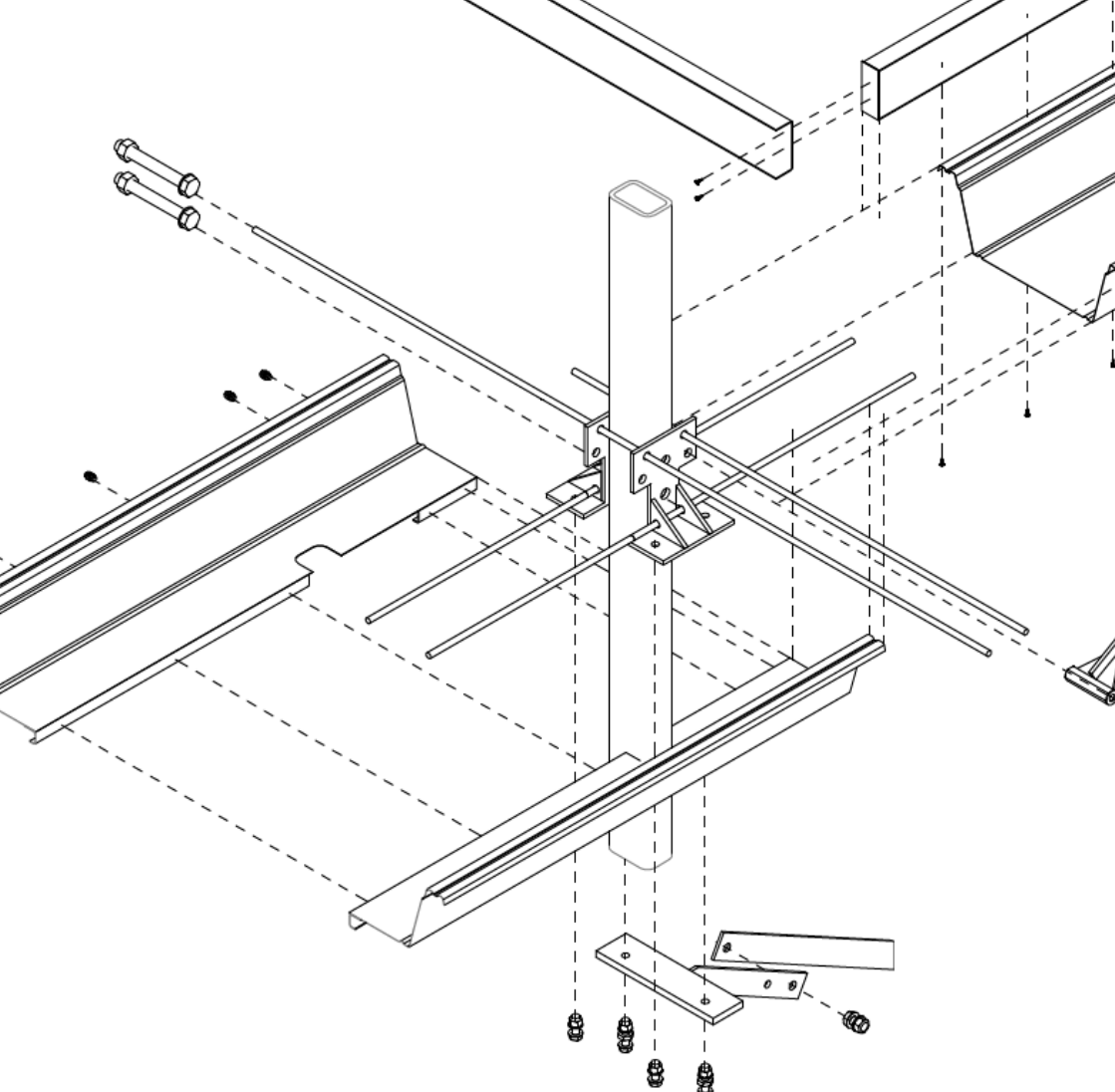

L01-B-2
Detailed components

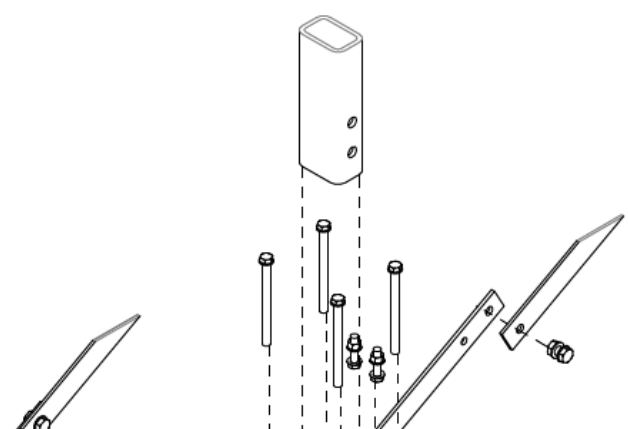

Table of Contents

1	Context + introduction
Section 1	The Platform approach
9	Defining platforms
27	The value proposition for platforms
35	Bridging the gap between construction + manufacturing
67	Platform case study: Platform 2
89	Sub assembly case study: Superblocks
Section 2	Potential impact
113	Transformational change through existing open platforms
121	New business + commercial models
Appendix	
135	Further reading

Acknowledgements

This book was produced by Bryden Wood Technology Limited with input from The Manufacturing Technology Centre, the Ministry of Justice, the Infrastructure and Projects Authority, The Dyson Project and Easi Space Ltd.

All images © Bryden Wood Technology Limited except:

Easi Space	photographs on pages 63, 90, 96, 97, 98, 99
MTC	page 65, photograph page 59
The Dyson Project	page 31
Others	page 11

© Bryden Wood Technology Limited 2018

Revision	Status	Date	Changes
1	S0	07.03.18	Initial issue for comment
2	S0	22.03.18	Issue at MTC event
3	S0	20.07.19	Graphics updated
7	S0	07.01.21	Minor amendments. URL updated. CIH logo added

For other Platforms books + videos:

 brydenwood.co.uk/ideas/178/

Click on links for:

 **Bryden Wood**

 @brydenwood

 brydenwood

 @brydenwoodtech

Context + introduction



Context

In July 2017 Bryden Wood issued the first book in this series entitled 'Delivery Platforms for Government Assets - Creating a Marketplace for Manufactured Spaces' (see link on the 'Contents' page). This set out a strategy for implementing the following vision:

Government will use the scale of its construction portfolio to help transform the market for creating high performing assets which improve the service for users, citizens and society and build a highly skilled and productive workforce.

It will improve the performance of assets towards international benchmarks, delivering enhanced quality, lower carbon and increased whole life value.

It will develop advanced manufacturing capability, products and services in the UK that could be exported globally.

This document was predicated on work for the Ministry of Justice and the Education and Skills Funding Agency to develop an evidence-based design process and manufacture-led construction approach using standardised and repeatable components.

It was followed by a document entitled 'Data Driven Infrastructure: From digital tools to manufactured components'. This set out initiatives that have been deployed by clients including Highways England and Crossrail and could be replicated as a standardised approach across a range of horizontal infrastructure projects in the transport and utilities sectors.

The intention of these two documents was to demonstrate how best practice could be implemented at scale by cross-fertilising these initiatives across other government departments.

In November 2017 the Autumn Budget reiterated Government's commitment to improving the construction sector, setting out the following undertaking:

The government is taking a series of steps to improve the cost effectiveness, productivity and timeliness of infrastructure delivery.

The government will use its purchasing power to drive adoption of modern methods of construction, such as offsite manufacturing.

Building on progress made to date, the Department for Transport, the Department of Health, the Department for Education, the Ministry of Justice, and the Ministry of Defence will adopt a presumption in favour of offsite construction by 2019 across suitable capital programmes, where it represents best value for money.

The Autumn Budget also confirmed that a Construction Sector Deal would support innovation and skills in the sector, including investment through the Industrial Strategy Challenge Fund.

The Budget was quickly followed with the release of a number of documents in November and December 2017 providing further detail on the vision and the strategy for its implementation:

- The Industrial Strategy white paper 'Building a Britain fit for the future';
- 'Transforming Infrastructure Performance' released by the Infrastructure + Projects Authority (IPA);
- The National Infrastructure + Construction Pipeline, also released by the IPA;
- 'Transport Infrastructure Efficiency Strategy' produced by Department for Transport, Highways England, Transport for London, Network Rail and HS2.

Introduction

The purpose of this document is to build on the publications listed above by setting out how a manufacture-led approach to construction would support the commitments made by Government. In particular, it sets out how a platform-based approach, common in the manufacturing and software industries, could be adopted by the construction sector and the benefits this could unlock.

The document 'Delivery Platforms for Government Assets - Creating a Marketplace for Manufactured Spaces' described a digitally enabled process, from briefing, through design to the manufacture and assembly of a new asset.

Since its publication much work has been done with the Ministry of Justice and the Manufacturing Technology Centre (MTC) to put into practice a number of the aspects of the 'Delivery Platforms' strategy. As well as developing and physically prototyping some of the key platforms, the standard manufacturing processes that would allow their large scale adoption have also been tested.

It is therefore now possible to move from a theoretical postulation to crystallise a new process based around the planning, design and integration of platforms.

The first section of this document sets out:

- What are platforms?
- Their value proposition;
- How standardised manufacturing processes could be harnessed to accelerate their adoption;
- A detailed case study of a platform and a sub-assembly.

Having established this, the second section of the document goes on to consider the positive impact that platforms have had on other industries, and how these changes could be harnessed for the benefit of the construction sector.

The world is currently experiencing the perhaps the fastest rate of technological advancement in its entire history, and there are numerous recent examples of entire sectors being positively disrupted by new ways of working. These in turn have led to

new service offers, new business models and sometimes a dramatic shift in the dominance of the sector's most prominent organisations. This section therefore covers:

- Two examples of platforms (one physical, one digital) that have had a transformational impact on the global economy;
- How the adoption of platforms could be made widespread;
- The potential new ways of working that this would facilitate.

While this is by no means to be considered a prediction of what the future holds, it is intended to prompt a debate about the future of construction and what a manufacture-led sector may look like.

Why is the industry ready for this approach?

The 'offsite revolution' has been discussed for many years, with only marginal increases in adoption. However, the conditions now seem right for a fundamental shift in the industry:

- Issues relating to construction cost, availability and labour availability and productivity, fragmentation in the market etc. are all well documented;
- Shared global drivers - United Nations figures estimate that the world's urban population will increase by 2.5 billion by 2050. This creates a need to be able to design and deliver assets in a highly efficient manner to keep pace with demand;
- BIM is increasingly becoming 'business as usual', so the digital tools that would support a manufacturing-led approach are in place. This a precursor to more sophisticated digital controls and workflows;
- Other technological advances in the digital, manufacturing and commercial sectors that could be harnessed by a platform-based approach.

Section 1

The Platform approach



Defining platforms



What are Platforms?

Platforms are sets of components that interact in very well defined ways to allow a range of products and services to be produced. The term has been appropriated from the software and manufacturing industries, where systems based around platforms have both supported rapid innovation and formed a basis for exponential growth and value.

The diagram on the right shows familiar physical and digital examples. Industries that have adopted a platform-based approach have experienced the following benefits*:

- Savings associated with transactional, fixed costs;
- More efficient product development processes through the re-use of common elements and adoption of 'modular' designs (in this context 'modular' relates to conceptual elements of design rather than physical modules);
- The ability to quickly evolve secondary or derivative products, and flexibility in product feature design;
- The ability to broaden the applicability of a product to meet changing customer needs and keep pace with technological advances while maintaining economies of scale;
- The ability to adopt 'mass customisation', combining the flexibility and personalisation of custom-made products with the low unit costs associated with mass production (this is the top right box on the matrix on the following page).

This approach is typified by 'continual improvement' - the components are improved or expanded over time by incorporating lessons learnt and innovations in materials science and manufacturing processes. This is very different to the 'constant reinvention' of traditional construction where there is a lack of standardisation and components tend to be designed from first principles for every new asset.

* For a more detailed analysis of manufacturing and software platforms, refer to Gawer, Annabelle, and Michael A. Cusumano. 'Industry Platforms and Ecosystem Innovation.' Journal of Product Innovation Management 31, no. 3 (September 4, 2013): 417-433.

Component> Platform> Product



Engine block

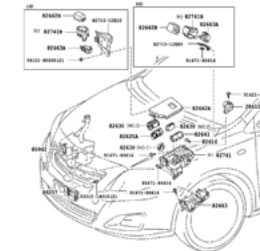

Chassis



Car



Shipping container



Global freight infrastructure

Low cost, reliable global trade + supply chains



Uber



iPhone

Peer-to-peer ride sharing, food delivery and transportation network

Physical and digital examples of platforms

What are Platforms? cont'd

Construction platforms would be made from components (products or sub-assemblies manufactured by a range of suppliers), with known interfaces, that could be combined in a consistent and well-defined way to create high performing assets (see diagram on pages 14 - 15).

A platform is an integrated system. Its purpose is to rationalise the assembly of components or parts in order to reduce the labour burden while providing for sufficient flexibility of customisation to ensure that the optimum long-term functionality of a building or asset is assured. The diagram on the right would place platforms in the top right corner, whereby highly bespoke assets are created using standardised processes.

Platform design is a digital process where a designer seeks to provide an optimum functional and aesthetic solution whilst being cognisant of and (where possible) adhering to the rule set of an appropriate construction platform.

The incentive for designing with or within these constraints is to unlock the efficiency benefits of the platform or integrated system. This can be mapped onto a graph of efficiency vs. effectiveness, where:

- Effectiveness is the ability of a building or asset to deliver its required business or social outcome;
- Efficiency is the total whole life cost required to achieve this outcome.

Platform construction is an integrated, digitally-enabled logistics process bringing together components and sub-assemblies.

The high-level test of platform efficiency

A platform must reliably deliver reductions in cost and time at equal or superior quality compared to traditional construction, when the rules and or constraints of the platform have been reasonably adhered to by the designer. This test will be expanded upon in the 'value proposition' section.

Diagram from 'Delivery Platforms for Government Assets'; while manufacturing sectors are able to achieve bespoke solutions using standard processes, there is a market failure barrier which exists in construction. Aggregated government spend, as set out in the 2017 Autumn Statement, would allow this barrier to be overcome by investing in platform-based solutions.

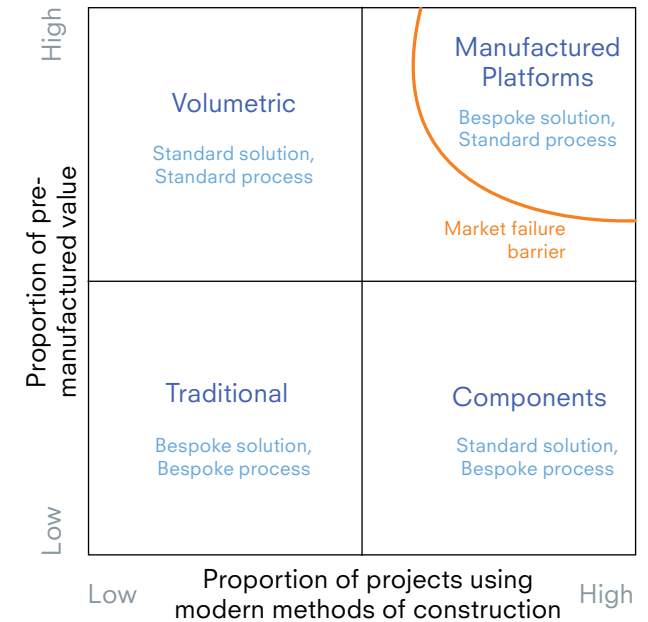

Efficiency vs. effectiveness graph showing how platforms should be tested

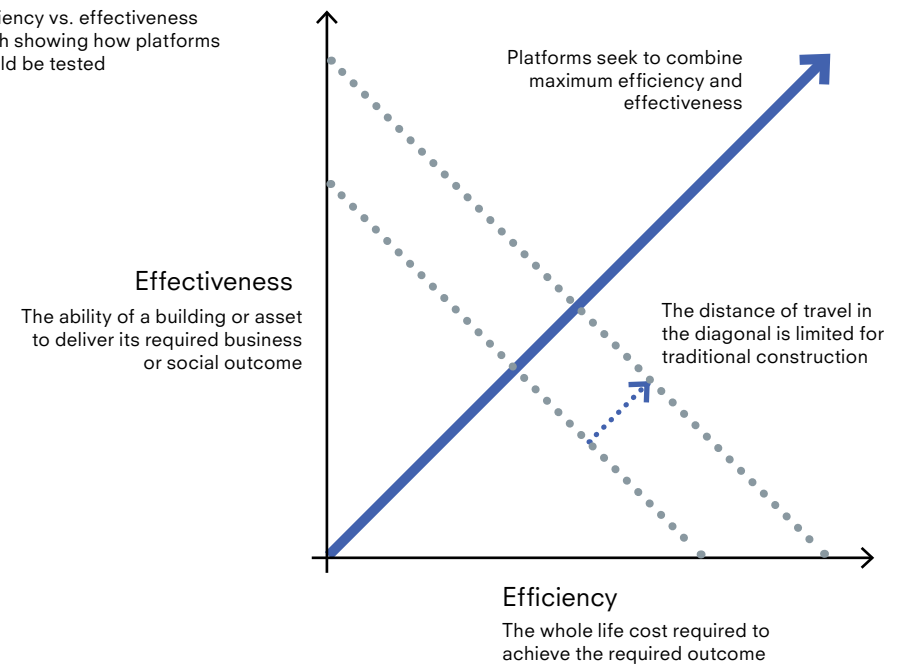

What are Platforms? cont'd

Platforms consist of...

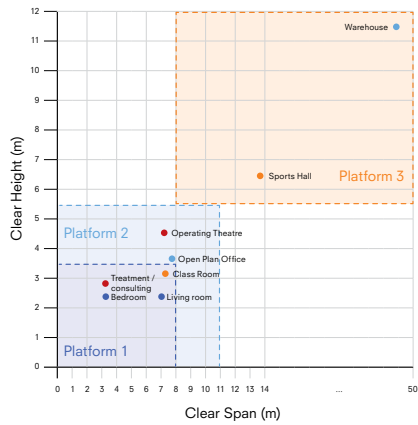

Components

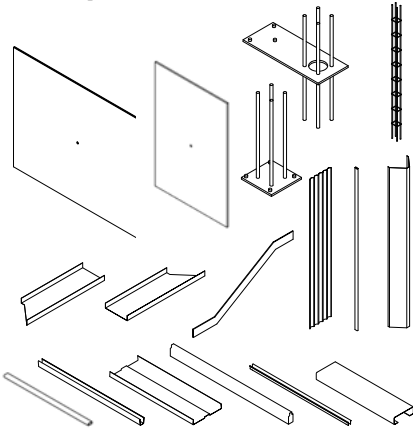

Products

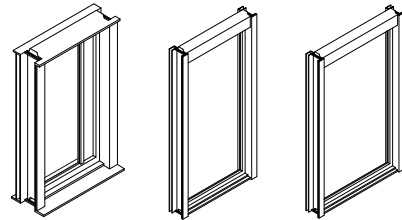

Components, products + sub-assemblies may be used in multiple Platforms

Standardised manufacturing processes

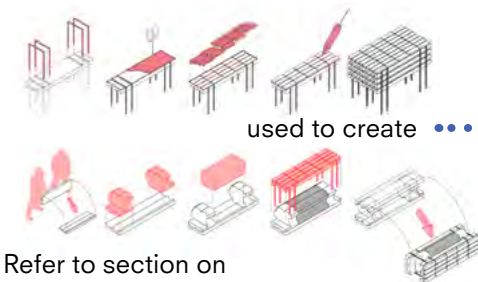

Refer to section on Sub Assembly Workstations

Defined connections + interfaces

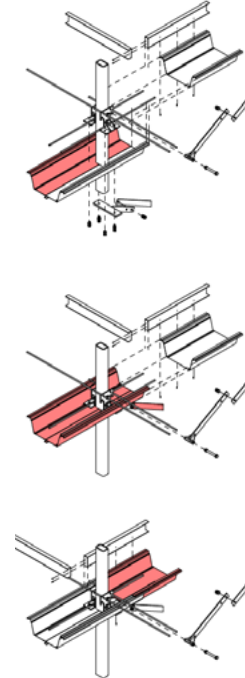

Sub-assemblies

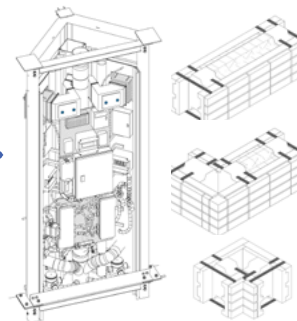

High performing assets, networks + systems

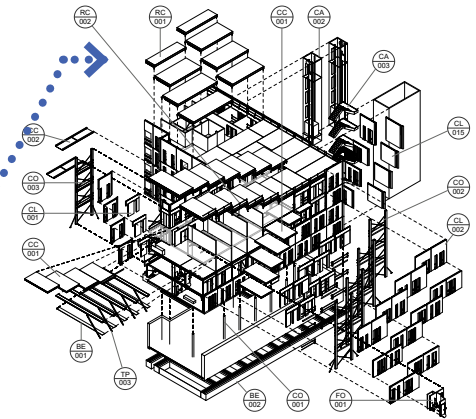

© Bryden Wood Technology Limited 2018

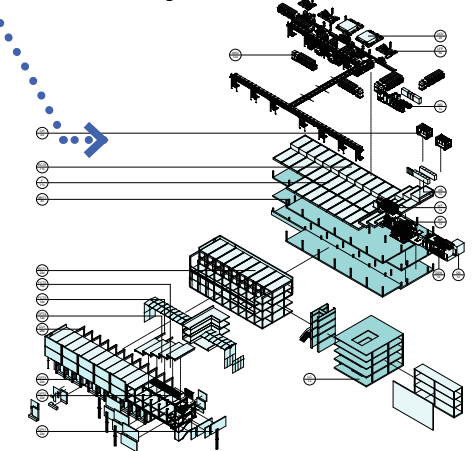
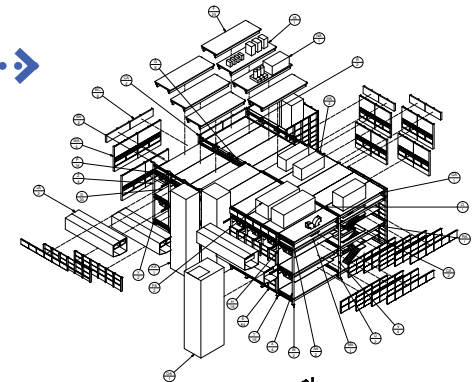

What's different about platforms?

Products vs. platforms

Construction already incorporates manufactured products and systems into its processes. This raises the question of how platforms can offer significant benefits over and above these existing systems.

Typically, existing products offer value to the manufacturer in the form of profits from sales while not necessarily passing that value on to the supply chain or end client. Improvements in the product drive incremental increases in value to the manufacturer (in the form of greater profits and / or market share).

Existing construction brings together a range of these systems and products, where benefits are 'external-facing' i.e. captured by the supply chain.

By contrast, a platform-based approach is designed to maximise the overall efficiency and effectiveness of the whole system, creating cumulative gains.

Platforms are the link to manufacturing

'Delivery Platforms for Government Assets' summarises numerous recent reports outlining the shortcoming of the construction industry and the need to emulate some of the successes of the manufacturing sector.

Platforms are the link between a highly productive manufacturing sector and the construction industry, and much of this document will describe the shift that platforms facilitate towards a widespread and scalable manufacturing approach.

Typical construction systems seek to maximise benefit for the manufacturer or supply chain

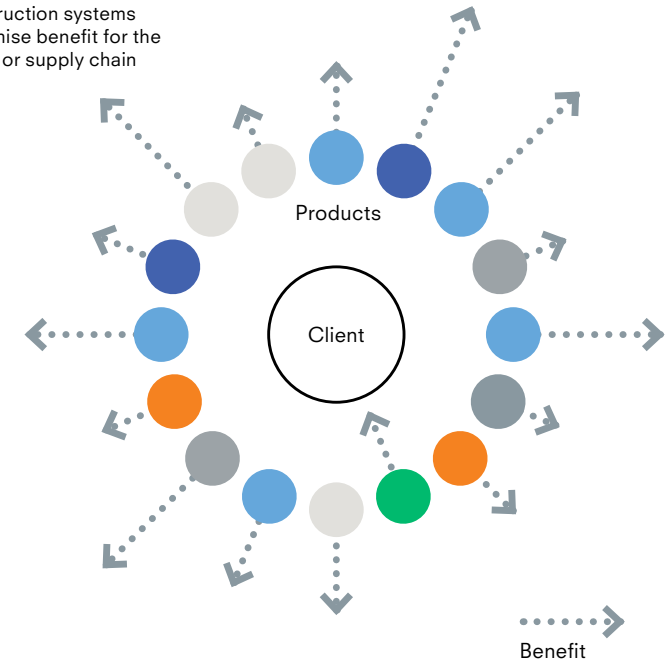

Platforms-based approaches seek to concentrate benefit and create a self-reinforcing system

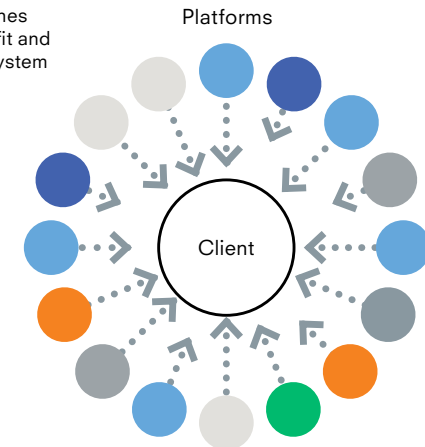

Physical vs. support platforms

The Digital Built Britain documents 'Delivery Platforms' and 'Data Driven Infrastructure' describe how increasingly interdependent the physical components that make up assets are becoming on their digital representations.

In the integrated systems that make up platforms, the physical components are part of a system that include supporting processes, tools and infrastructure to maximise benefits in their delivery and use; the link between these is inevitably digital.

The case studies in section 2 of this document describe two of the most successful and ubiquitous open platforms, which both exhibit highly intrinsic links between physical components and their supporting infrastructure:

- The invention of the ISO shipping container changed the world economy. However, the benefits of this standardised box have been hugely amplified by the digital systems that match customers with carriers, optimise and track container placement on ships and in docks, drive automated cranes (and, in the near future, vessels), track shipments etc. and the physical transportation and storage networks that span the globe;
- The iPhone is the world's best ever selling product, but sales were relatively slow until Apple allowed third party developers to create apps for the phone and opened the App Store; the phenomenal success of the iPhone is in large part because it is a means to access products and services via the App Store. It allows SMEs to compete on the same terms as major players, and has lowered the barriers to entering the global market. It is anticipated that App Store revenues alone will be higher than global box office receipts in 2018, while the total 'app economy' is predicted to grow to \$6.3 trillion by 2021.

This document will explore issues relating to both the physical components, and the supporting functions needed to maximise their benefit.

Physical platforms are considered in terms of 'specific' and 'open' platforms, which are described on the next pages. Support platforms are considered later in this document, and include:

- Manufacturing processes;
- Competent labour;
- Supply chain nodes e.g. consolidation centres and logistics hubs;
- Procurement tools and processes.

Specific vs. open platforms

Specific platforms

'Specific platforms' are systems developed for a particular organisation (e.g. a manufacturer or client). Creating a new manufacture-led solution and bringing it to market is very costly and involves significant risk. This high barrier to entry limits the number of organisations who can undertake this process. Those that have been successful are typically protective of their IP since they hope to maximise their market share in order to recoup their investment.

This results in multiple organisations developing very similar solutions in isolation from each other, and the rate of evolution is inefficient and slow.

Specific platforms can be thought of as 'physical IP' - where a client has a specific, repeatable asset type then platforms can provide the benefits listed here as well as speed to market.

Certain clients (for example GlaxoSmithKline and Ministry of Justice) have already developed and are achieving benefits from their own internal platforms.

Open platforms

'Open platforms' are those that are developed by one or more companies, but made widely available for others to adopt, which they may do in a number of ways:

- Adding to the component or product sets;
- Contributing innovations in materials or manufacturing processes to expand the platforms' capabilities;
- Developing new, complementary products or services (which may be related to e.g. procurement or payment, rather than the physical components themselves).

One of the most powerful ways that open platforms have been effective in other sectors is through network effects which can cause adoption to grow exponentially. This occurs when the growing network of users, contributors and supply chain

members start to gain the benefits of platforms, creating a positive feedback loop that incentivises still more users and contributors to adopt the platform and join the ecosystem.

It is proposed that this effect could be achieved in construction by making Government platforms (including those already developed by MOJ) open source and removing the barriers to entry. The benefits of such an approach would be:

- Aggregation of government demand into a sustainable pipeline providing the supply chain with the ability to plan investment;
- Benefits of scale could immediately be achieved by making the market for platforms as wide as possible - even the smallest projects could benefit from platforms that were developed for large programmes (i.e. the industry could largely shift from a 'project' mindset to considering 'assets', 'systems' and 'networks' as set out in 'Transforming Infrastructure Performance');
- The cost of developing, prototyping and refining platforms could be amortized over a much larger share of the market than any individual organisation could achieve, which would immediately lower the risk profile associated with developing new solutions;
- The range of companies that could benefit from and contribute to the creation and refinement of platforms could increase exponentially;
- By expanding the market for platforms, all participants (including, and perhaps especially, every UK tax payer) would share the benefits;
- Any improvement in the design, manufacture or assembly for any repeatable component would be achieved many times;
- The focus on client- or project-specific differentiators would become more sophisticated to further stimulate innovation;
- The work of designers would be more tightly focussed on the creative challenges posed by the project specifics, with no need to continually 'reinvent the wheel'.

Establishing the boundaries of platforms

The division and classification of platforms for built assets requires careful analysis.

A platform is developed by considering the reasonable boundaries of what it might be able to effectively deliver e.g. it is unlikely that any single platform will be able to deliver everything from an airport to a single dwelling.

The more specific a platform is to a particular use, the more highly it can be targeted to deliver efficiency benefits. However, if a platform is too specific then it may be constrained by the size of the market it can serve and fail due to inadequate volume. Each platform therefore requires enough application to build sustainable volume, while limiting complexity enough to deliver efficiency.

'Delivery Platforms for Government Assets' sets out a process for defining platform characteristics. The process stages of developing functional platforms are:

- Analysis;
- Integration;
- Rationalisation;
- Optimisation;
- Systemisation.

'Delivery Platforms for Government Assets' set out a broad definition of the performance characteristics that a number of highly utilised platforms would possess, based on:

- Physical dimensions;
- Building height;
- Level of complexity;
- Level of repeatability;
- Number of buildings.

The figure on the right is an initial view on those platforms that would be most commonly useful, and the type of assets that they could serve.

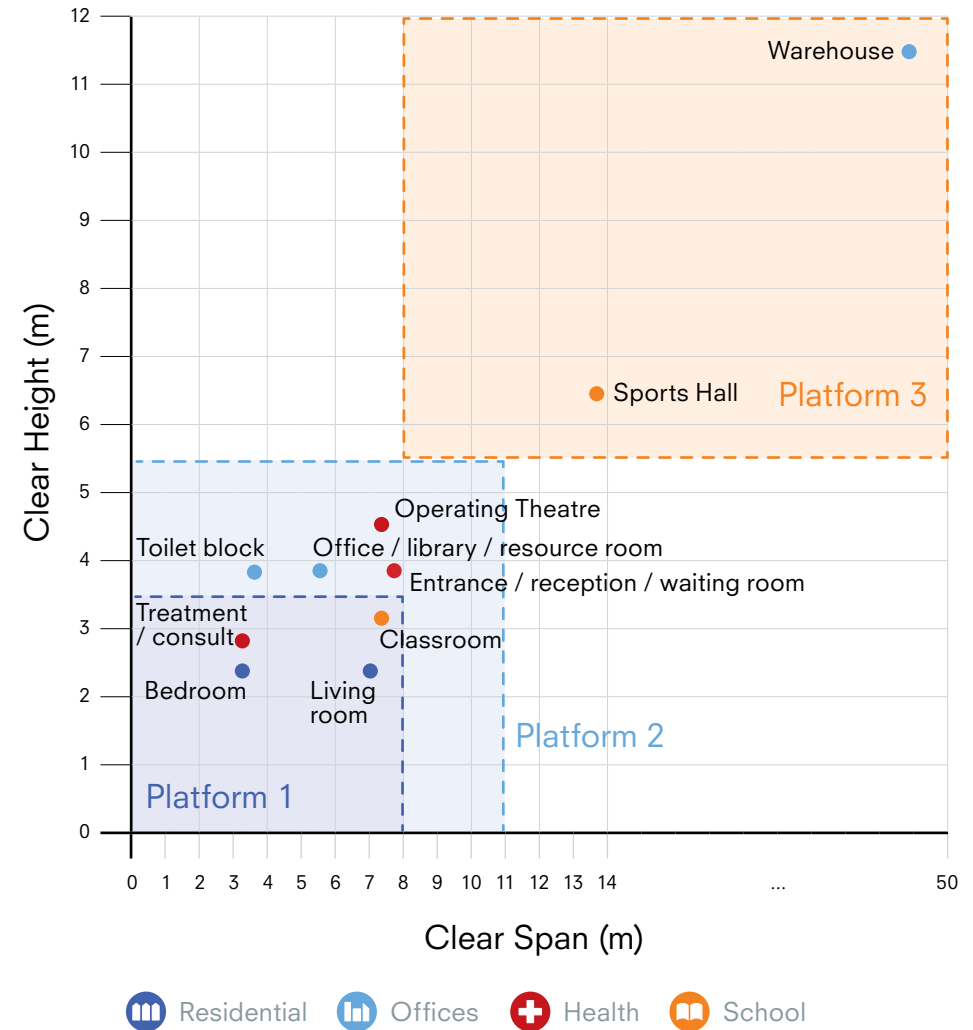

© Bryden Wood Technology Limited 2017

Establishing the boundaries of platforms cont'd

Level of complexity

Complexity will affect the degree to which the platform will need to incorporate a high degree of mechanical, electrical and public health services, from heavily serviced buildings with high operational and maintenance costs to simple buildings with relatively straightforward provision in terms of heating / cooling, lighting power distribution etc.

Level of repeatability

This would describe the overall degree of variation between the types of space or groupings of spaces within a particular asset.

A typical housing scheme, for instance, will have a mix of unit types from small flats to large apartments, with a different layout on different floors and is therefore highly variable.

By contrast, student accommodation is highly standardised with little meaningful variation between the majority of spaces and floors.

A factory making student accommodation using a robotic module manufacturing plant is an example of a highly invested and highly specific platform:

- It will be successful if the demand is high, consistent and relatively even;
- Benefit opportunities are high, but;
- Resilience to external factors is low

If, however, this singular investment was distributed and more generic i.e. able to service more market places and could be easily re-purposed then it would represent a more open platform.

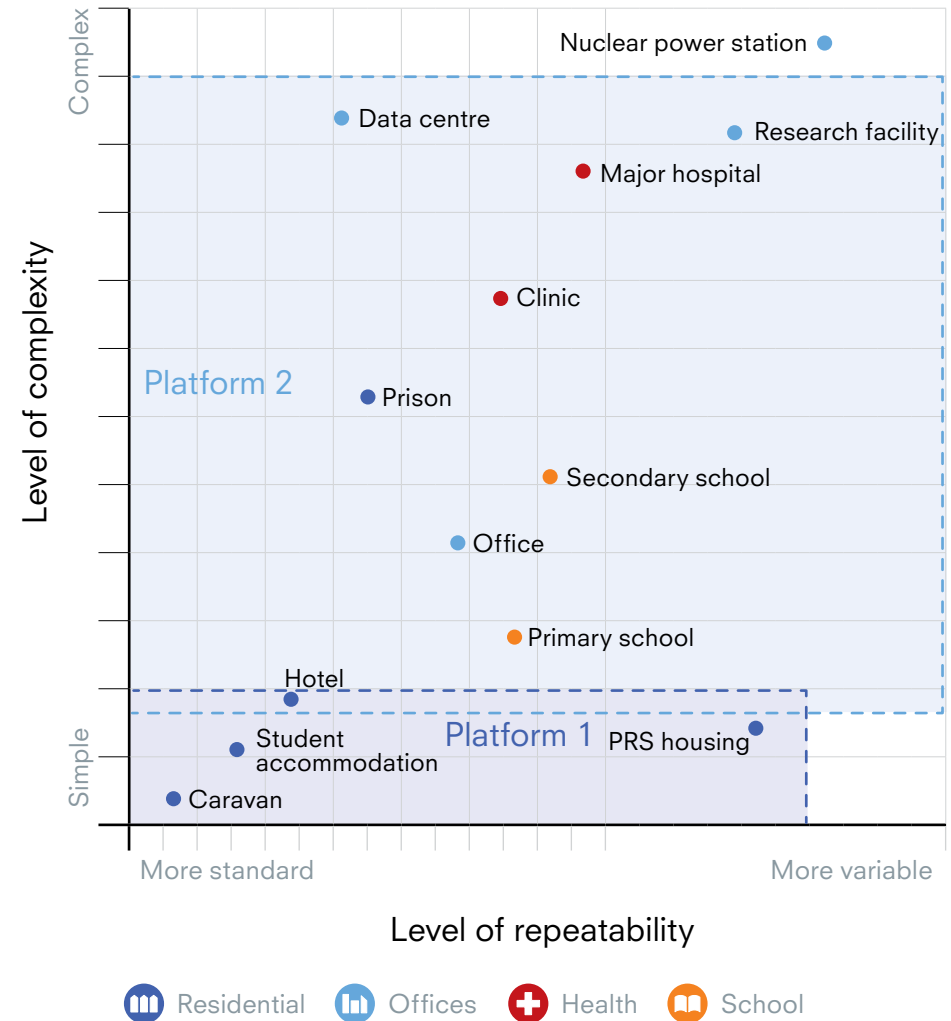

The value proposition for platforms



Defining value

The 2017 Autumn Statement refers to 'a presumption in favour of offsite construction... where it represents best value for money'

In addition, the IPA report 'Transforming Infrastructure Performance' includes a section on 'Benchmarking for better performance' - this covers the use of cost, schedule and performance benchmarks to support the selection, budgeting and design of projects.

It is therefore critical to have a strategy for benchmarking platform-based approaches against traditional construction across the whole life performance but initially at least in terms of capital cost.

Traditional 'top down' costing methodologies based on benchmark rates do not provide a ready way of assessing the benefits of a Platform-based approach, since:

- There is no existing benchmark data for new systems;
- Very often a single DfMA element comprises components from multiple packages (architectural, structural and MEP) and therefore does not work well with procurement using traditional packages and Work Breakdown Structures;
- The benefits of DfMA often accrue from a variety of areas including preliminaries, logistics, labour (lower rates and higher productivity), lack of rework etc. which are hard to quantify using a 'top down' approach.

Meanwhile, 'Delivery Platforms for Government Assets' set out a number of strategic value drivers for a platform-based approach:

- Maximise residual asset whole-life value;
- Optimise the 'product';
- Eliminate or minimise risk;
- Create flexible components that can be used across programmes for a variety of building types;
- Facilitate highly planned and coordinated logistics from manufacture and supply chain through to activities on site;
- Use low skilled or upskilled labour;
- Develop standard processes for manufacture and assembly.

The efficiency vs. effectiveness of platforms should encapsulate whole life performance, which is increasingly considered in delivering assets (and is referenced in 'Transforming Infrastructure Performance').

However, as the industry moves towards a more manufacturing-led approach, it may be necessary to import other concepts that are used to measure value in other sectors. These are described briefly on the following pages.

Government department framework analysis: overview of various costs associated with a typical project - of every £ spent, just over 51% results in residual asset value for the client.

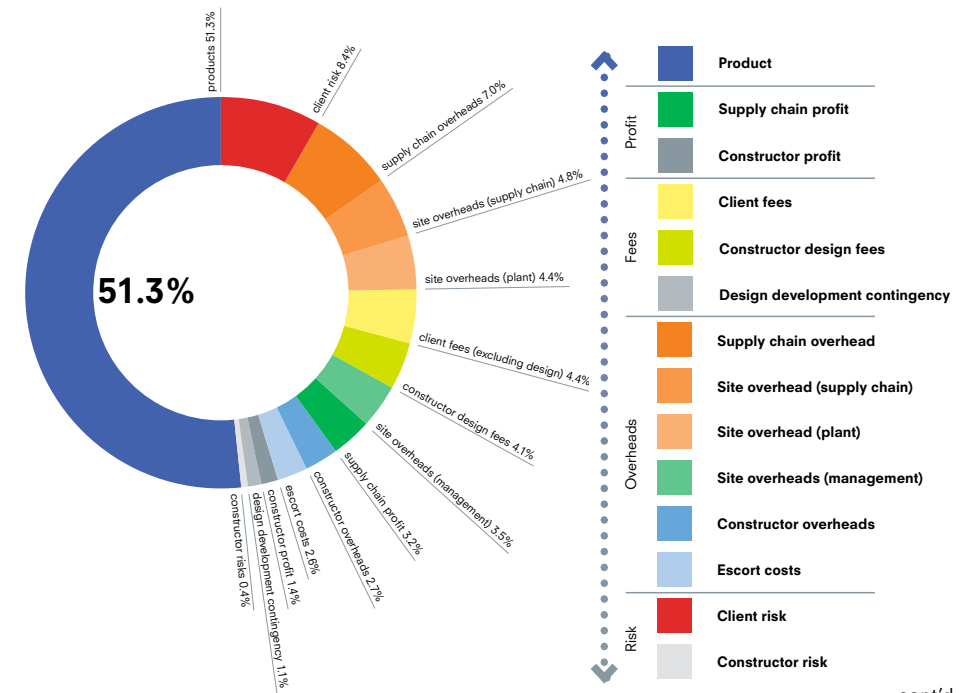

Defining value cont'd

Net present value

Net present value (NPV) is a measure of the costs (outgoing cash flow) vs. the benefits (incoming cash) of an investment within a set period. The graph on the right shows how a platform-based approach seeks to optimise maximise net present value by:

- Reducing the capital investment;
- Shortening the period between outgoing and incoming cash flow (by maximising speed of delivery);
- Maximising residual asset value.

Note the NPV curve may be different for each stakeholder which should be carefully considered in understanding the value drivers for a specific project or programme.

Functional product cost

There is inevitably a difference in the value of a product or asset (as perceived by the customer) compared to the cost of delivering it (which includes materials, labour, logistics, overheads etc.)

The benefits of platforms would be in properly understanding what is valuable to the customer (whether client or end user) and seeking to reduce the non-value adding costs associated with delivering this value.

Conversion cost

Conversion costs are the total costs of converting raw materials into finished products; they include direct labour, manufacturing production costs and overheads. They exclude the cost of the raw materials themselves. In order to maximise residual value a key aspect will be to minimise conversion costs associated with the platform components by using highly productive manufacturing processes and labour.

Net present value (NPV) curve for investment in a new asset.

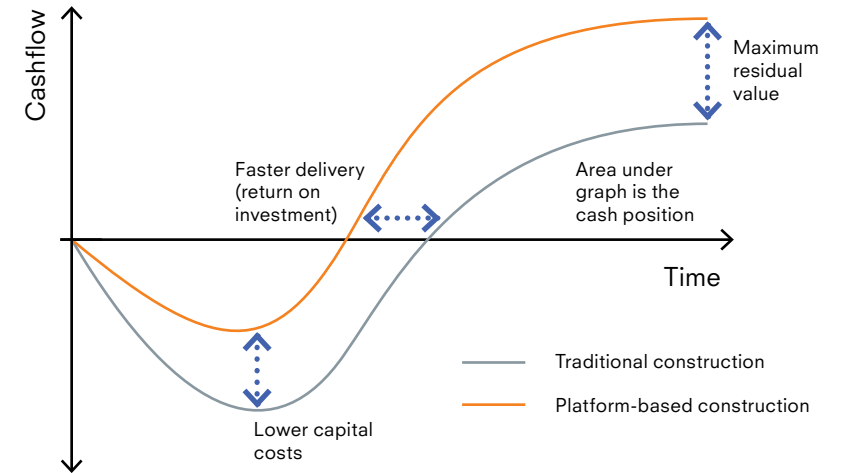

Defining value cont'd

The test of platform efficiency

In line with the earlier efficiency vs. effectiveness graph, a platform based approach must deliver whole life customer value that is equal to or exceeds traditional construction.

However, in order to maximise efficiency it should do so while requiring:

- The least amount of raw material;
- Handled and / or moved:
 - The fewest number of times;
 - Through the least amount of processes;
 - By upskilled and / or highly productive people
 - By the fewest number of people overall;
- Delivered to site at the right time, in the right sequence, with the correct information.

Analysis by a central government department on projects carried out under their construction framework shows that achieving the criteria listed above would deliver significant improvements.

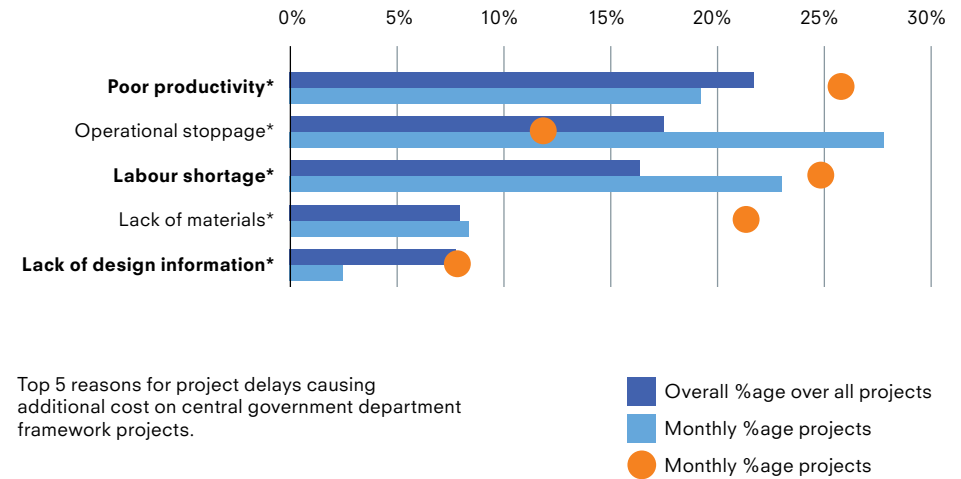

Bridging the gap between construction + manufacturing



Introduction

The subtitle of this document is ‘bridging the gap between construction and manufacturing’. This section starts to describe in more detail how this link can be made now that platforms have been defined.

One of the aspects of platforms is their ability to leverage highly repeatable components. This is a useful link to manufacturing; in traditional construction every building is a prototype, so every element is treated as such. Any productivity gains achieved over the course of a traditional project are likely to be lost; there is no formal repository for the dissemination of learning, and so little incentive to capture it.

A platform based approach as outlined here would have some immediate benefits:

- Standard products lend themselves to the use of manufacturing processes;
- The wide adoption of platforms would create a consistent pipeline that facilitates a manufacturing-led approach;
- The use of the same components across multiple projects would allow the continual capture and broadcast of best practice and evolution over a much longer time frame than any individual project;

This section will describe how platforms are manufactured in line with the ‘test of platform efficiency’ defined earlier.

The diagram on the right shows the creation of sub-assemblies as the key manufacturing step (highlighted) whereby raw materials or commoditised products are turned into sub-assemblies. Processes prior to this are carried out by existing manufacturers, processes after this are at the final point of assembly. This section will therefore describe what happens in this crucial transition (where conversion cost is particularly important).

The focus on manufacturing processes allows platforms to be described at a more fundamental level. While there will be multiple platform types, the manufacturing processes used to create them may be more generic i.e. to use a manufacturing

example, laser cutting is now a common way of cutting sheet material. The same process is used regardless of the shape that is being cut, the material that it is being cut from or the thickness of that material. The same process can also be used no matter many times it is needed, from one off bespoke items to mass produced commodities.

One useful analogy is the creation of an alphabet, a limited character set that can nonetheless be used to communicate every idea in every language that uses the alphabet. If platforms are ‘words’ (used in different asset types or ‘languages’) then ‘manufacturing’ is the ‘alphabet’.

This section will start by expanding on this alphabet analogy.

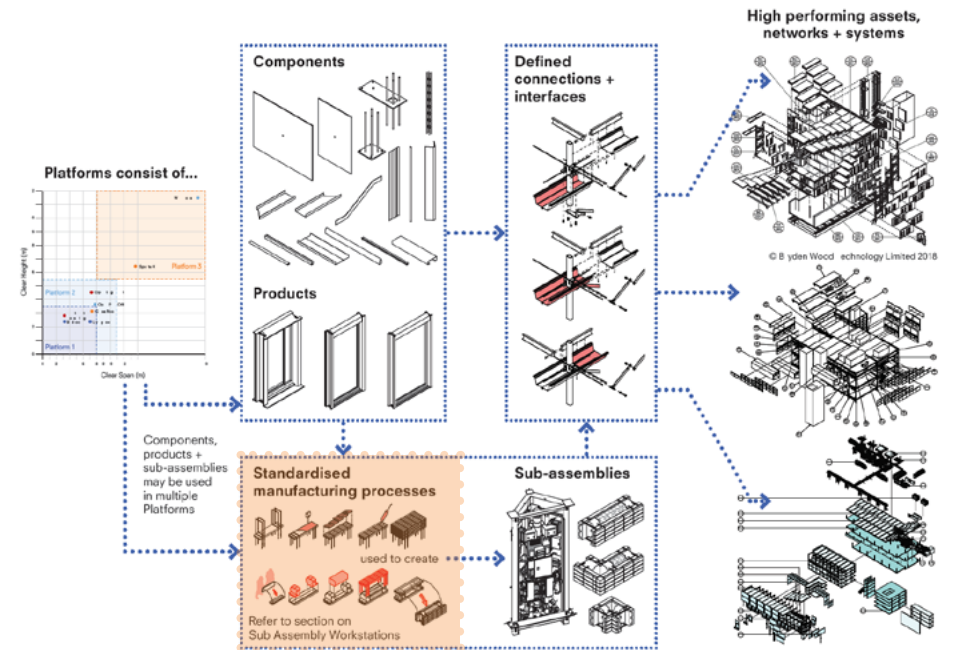

Platforms diagram used previously, with the sub assembly manufacturing process highlighted

The alphabet effect

Written and other graphical forms of communication rely on abstraction i.e. things in the real world are represented by lines and symbols which convey meaning.

Early forms of written communication were a first order of abstraction, whereby each symbol was a specific representation of a single object; this relied on a 'one to one' relationship between a symbol and the object that it conveyed. As a result, Egyptian hieroglyphs, by way of example, numbered around 5,000, it was difficult to communicate precise messages that were not open to interpretation, and it was almost impossible to convey abstract concepts.

A huge breakthrough in human understanding and intellect occurred with the invention of the alphabet. This second order of abstraction allowed a small number of symbols to represent any object or concept, real or imagined.

'The Alphabet Effect' is a series of hypotheses arguing that the invention of an alphabet was a precursor to humankind's ability for abstraction, analysis, coding, decoding, and classification. In short, the creation of an alphabet fundamentally changed how we think and accelerated the sophistication of that thinking.

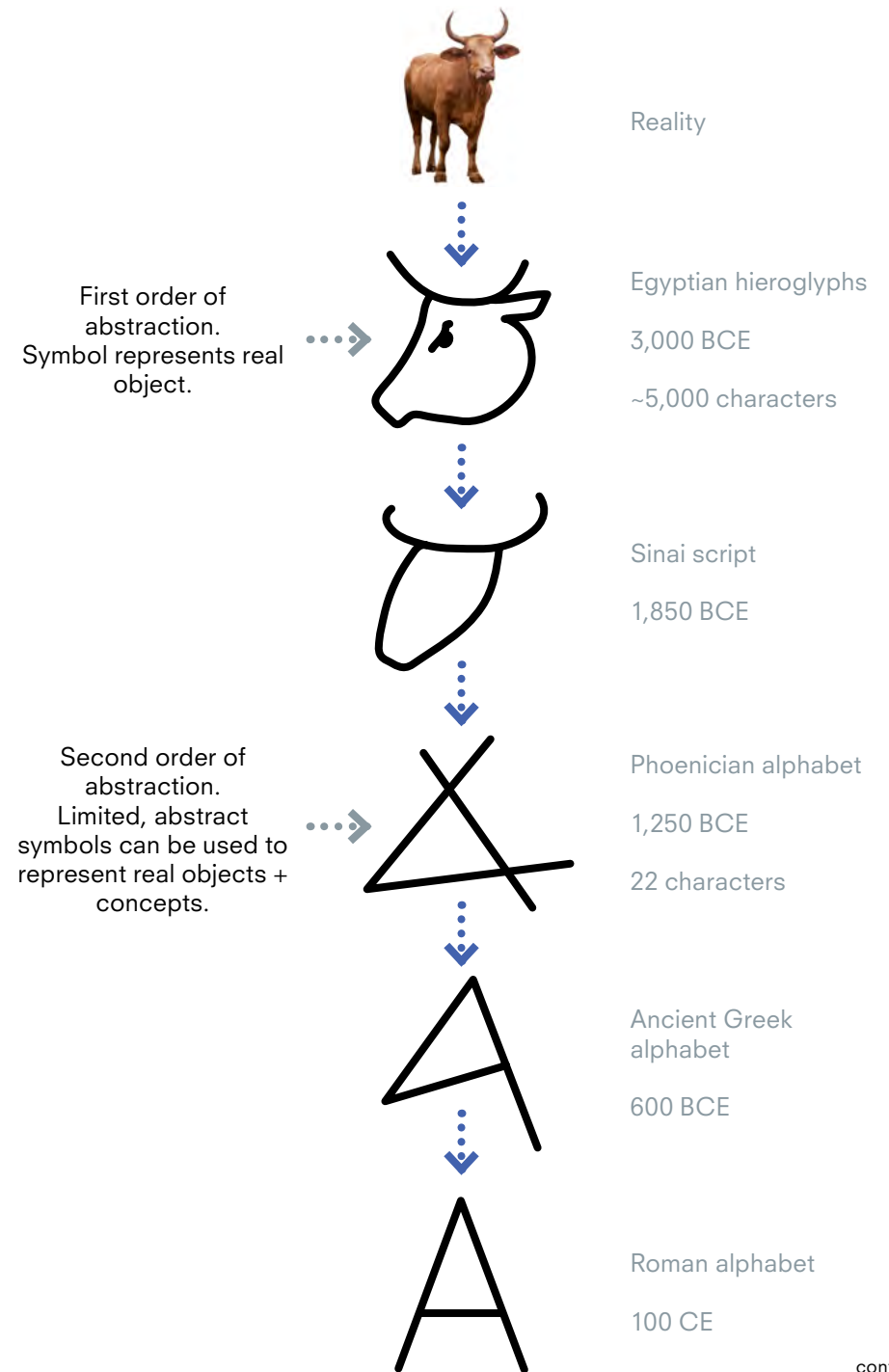

The alphabet effect cont'd

The adoption of a platform-based approach is a vitally significant step in driving a more productive industry. However, although platforms play an important part of the process, the understanding of platforms alone will not facilitate the change we need within the industry.

In order to facilitate the delivery of platforms, it is critical that we identify this second order of 'characters' in the process, help us understand and clearly define how to manufacture platforms in line with the 'test of platform efficiency' defined earlier.

This, more limited, number of manufacturing processes provide the second level of abstraction; the consideration of not the component itself but its method of manufacture, could perform the function of the 'alphabet' and open this process up to the same range of benefits created by the alphabet vs. hieroglyphs:

- The number of people who could learn the 'alphabet' is very high;
- The same alphabet is applicable to multiple languages i.e. focussing on manufacturing processes would cut across sectors and asset types;
- There is no limit to the range of creativity and invention that can be achieved in literature, similarly we should expect no boundaries to what can be achieved through manufacturing-led construction.

The focus on manufacturing processes can therefore be undertaken while being agnostic to asset type, platform or even material (as in the laser cutting example).

In developing construction platforms to date for a range of clients and sectors, the limited 'alphabet' of manufacturing processes has started to formulate itself.

It is proposed that these should be formalised through the creation of generic, repeatable areas of work which would facilitate certain types of activity. For the purpose of this document, these have been termed 'Sub Assembly Workstations' (SAWs).

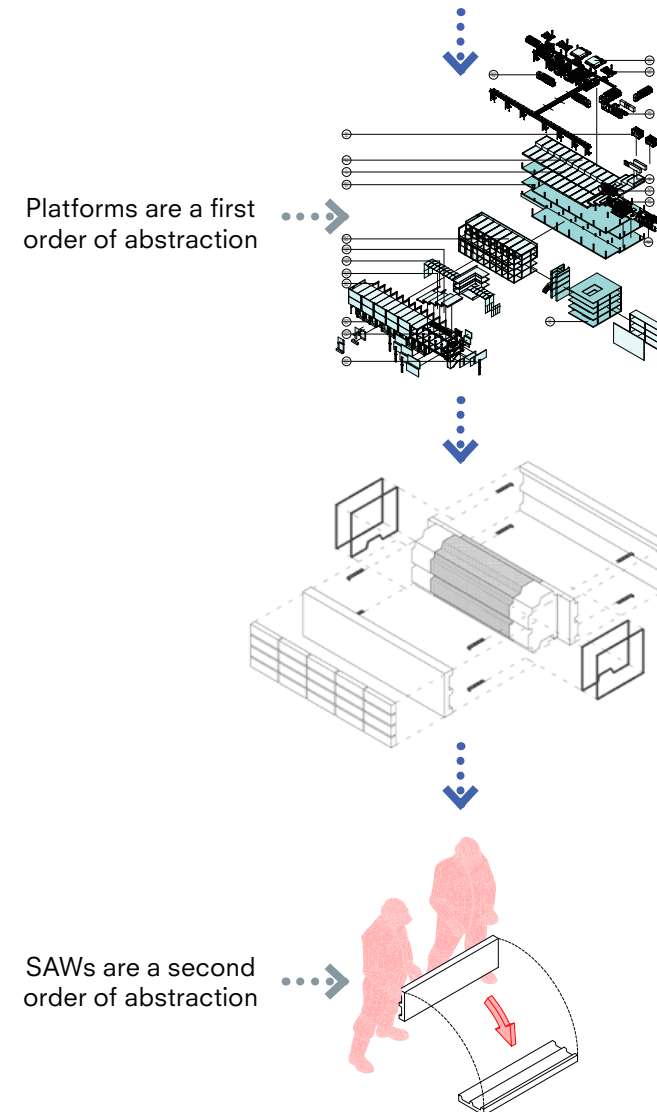

What are Sub Assembly Workstations (SAWs)?

A SAW (or 'letter' to continue the alphabet analogy) is a set of ergonomically designed assembly activities which effectively and efficiently create a platform. The initial SAWs that have been developed and tested for the case study platforms are:

- Cassette manufacture to avoid working at height;
- 3D manipulation to aid assembly;
- Bring the worker to the point of assembly of a large item;
- Linear processes.

Later in this section there is a more detailed description of each of the SAW types listed above. Before that, it is important to explain the relevance of SAWs as a fundamental function of a platform-based approach.

SAWs are how platforms are manufactured

Work with MTC has shown that the gulf between manufacturing and construction is considerable. However, SAWs create a space that is recognisable to both construction (especially given the relatively manual nature of the initial SAWs) and manufacturing sectors. This is the overlap into which manufacturers could reasonably step, using their experience with Advanced Product Quality Planning (APQP) etc. to help to fast track the adoption and evolution of a manufacturing-led approach.

This would also allow the supply chain for platforms to be opened up beyond the normal construction industry. Elements like the 'productised' risers, ceiling cassettes etc. could readily be manufactured by companies that would traditionally create wiring looms or other sub assemblies for automotive and aerospace.

Stitching the manufacturing supply chain into the delivery of major infrastructure projects through the use of SAWs and platforms should be an effective way of cross fertilising these two sectors and creating a bridgehead for the flow of expertise, capacity and capability.

The need for a range of SAWs (or letters in the alphabet) is derived from the range, scale and geometry of integrated sub-assemblies that are necessary to service a variety of platforms. For example, long linear sub-assemblies (pipework distribution etc.) will require significantly different operational assembly space, sequences, jigs and equipment.

The SAWs in a traditional manufacturing process would typically be located in a single factory facility although distributed manufacturing has become much more common.

Due to the, often, large scale of construction projects the distribution of SAWs is a significantly more important consideration although it is unlikely that a single factory facility would be used due to the economics of setting up a single facility of large enough volume to provide such an assembly process.

The distribution of SAWs and their throughput will be a factor in determining the buffer or work in progress required for the efficient operation of platform construction. This may be calculated using discrete event analysis software (e.g. Lanner Witness) which is common in manufacturing but not construction.

Intrinsic platform efficiency

The frequency of use of a SAW will be related to its functionality and the commonality of the task it seeks to address.

The investment in developing and optimising a SAW or product can be applied proportionately to its frequency of use. This may again be equated to language; the letters of the alphabet are all necessary but their frequency of use is unequal. Vowels are letters which are both commonly used and essential in the deployment of other letters. Similarly, certain SAWs will take the role of vowels, integrating other SAWs to achieve meaningful process 'grammar' or 'words'.

What are Sub Assembly Workstations (SAWs)? cont'd

Design

Manufacture

Assembly

Operation + social outcomes



Analysis, integration, rationalisation, optimisation



Platform selection or creation

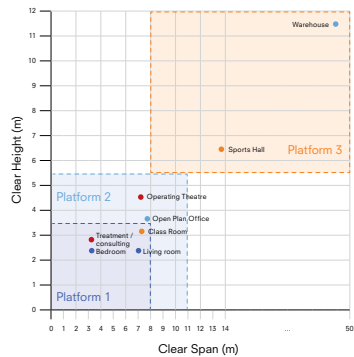

Full list of SAWs would expand over time to include robots / cobots / additive manufacture

Sub Assembly Workstations

Cassettes to avoid working at height (e.g. residential ceiling)

3D manipulation to ease assembly (e.g. riser)

Bring the worker to the assembly of large item (e.g. Superblock)

Linear processes (e.g. welding a beam)

Components + products

Defined connections + interfaces

Sub Assemblies

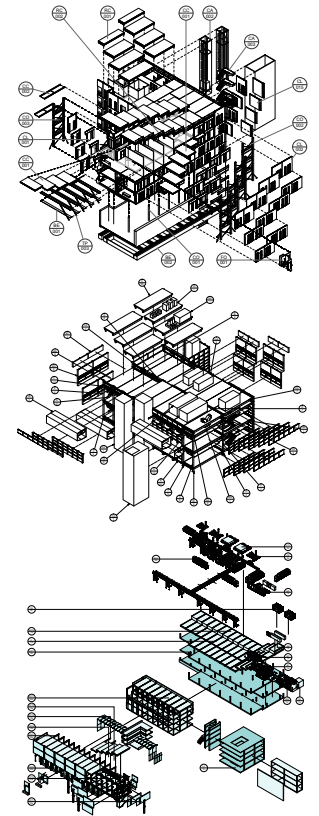

A SAW can be thought of as a node at which labour, information and materials are brought together. The 'test for platform efficiency' describes the need to use the least amount of material, processed in the most productive way possible. SAWs are an extremely effective way of achieving this.

The next section will set out how each of the elements listed above come together at a SAW.

SAWs are the meeting point of multiple aspects

Labour



Information

Skills + training
Standardised processes / APQP / standard operating procedures / guided instruction

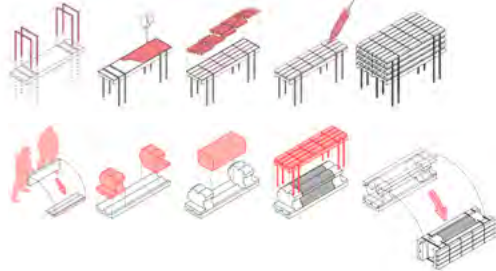

Materials

Existing products (+ those developed by manufacturers)

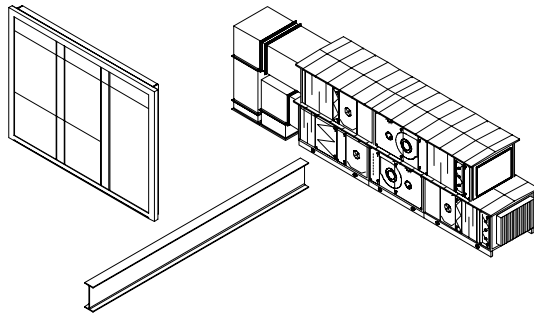

Products developed specifically for departments (may be applicable to multiple building types)

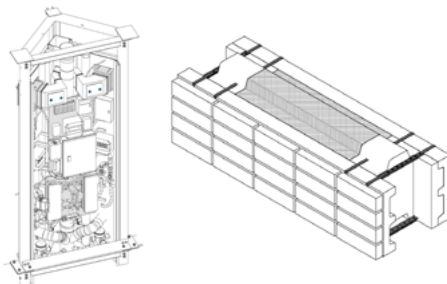

Manufacturing facilities

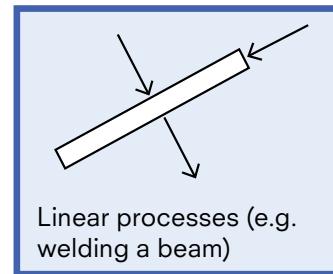
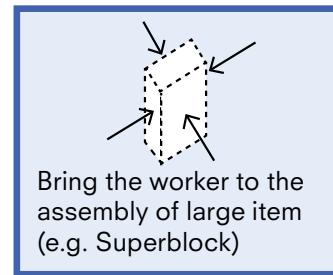
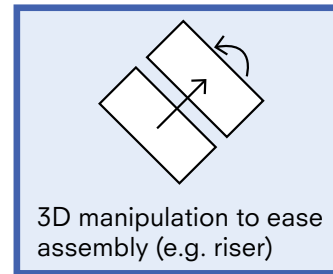
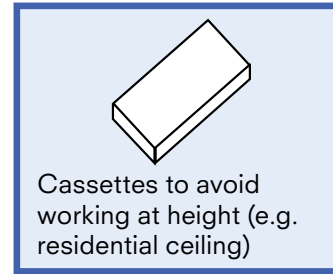

High performing assets, networks + systems

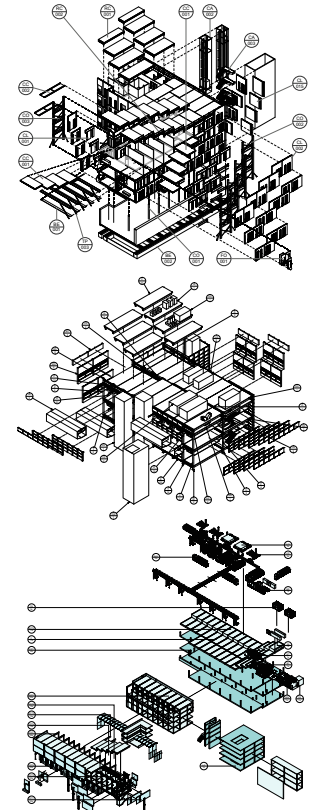

- Existing suppliers could already map their capability to SAWs
- SAWs become a unit of capacity + capability

Labour

The need to create a more diverse and productive workforce is well documented. One of the key aspects in developing SAWs is therefore that they should use the simplest assembly techniques possible. This effect is amplified by the general principle in developing platforms to use as little fabrication as possible - it inherently reduces the amount of labour required and the need for existing trades.

By ensuring that the tasks that take place at SAWs are straightforward, they require no previous knowledge of construction and very little training. This has a number of benefits:

- The range of operatives that are able to work in a SAW enabled environment is incredibly diverse;
- The time and cost associated with upskilling operatives is very low, which minimises the upfront investment and makes SAWs very agile (e.g. for creating temporary facilities or quickly creating a large, local workforce for major programmes).

GlaxoSmithKline's 'Factory in a Box' platform used a team of ex-Gurkhas who were trained to assemble highly complex pharmaceutical facilities. This demonstrated a 75% reduction in the amount of labour needed (compared to traditional construction) and exceptionally high levels of productivity.

Meanwhile, on the initial SAWs for the Ministry of Justice, a team of low skilled operatives have been trained to use SAWs and after minimal training have been able to assemble components that are indistinguishable from those assembled by skilled craftspeople (see the sub assembly case study).

There is a huge opportunity to link SAWs to future training programmes, and create courses which would provide a broad base of training in the most common SAWs. It is not difficult to envisage a future where schemes such as 'Skills Passports' could include types of SAWs along with levels of expertise.

Bottom: Low skilled, highly competent operatives who were trained to deliver complex facilities using GlaxoSmithKline's 'Factory in a Box' platform

Skills vs. competence

One of the most widely recognised issues in the construction industry is its fragmentation into numerous trades with deep but narrow specialisms.

It is worth noting how trades evolution have evolved over time. The earliest forms of construction were a collective effort, but over time and as construction became more sophisticated specialisms appeared e.g. thatcher, stonemason, lead worker. This developed into contractual structures with sub contractors, management contractors etc. which has resulted in 'contractually assured inefficiency'.

Meanwhile in manufacturing there has been a shift away from 'trades' and towards 'competences'. So cars are no longer made by engineers and mechanics, they are assembled by highly competent and trained operatives.

The use of SAWs would allow the 'decomposition' of trades, and their recrystallisation into 'competences'. It has already been demonstrated through the manufacture of 'Superblocks' (see the sub assembly case study) that SAWs can be used to create a highly competent workforce from a low skill base.

Basic SAW training would put in place generic competence, with additional task competence supplied via SOPs or guided instructions. It is also well known that repetition increases productivity so the adoption of standard processes would rapidly increase productivity (as has been seen in the initial manufacture of Superblocks where assembly times reduced by 50% within a few cycles).



Information

Skills training is one obvious set of information that could be linked to SAWs. Generalised SAW training would be enhanced by specific Standard Operating Procedures (SOPs) or guided instructions (a set of step-by-step instructions which operatives follow to carry out routine operations. SOPs and guided instructions are widely used in manufacturing to achieve efficiency, quality of output and uniformity of performance, while reducing miscommunication) for a particular sub assembly or product.

This is one area where continual improvement can be leveraged - any improvements in a process can be captured in a revised SOP, which can then be communicated to every operative to multiply efficiency gains. This is one means by which the manufacturing sector has seen vast improvements in productivity over time.

It is also envisaged that data from a coordinated model could be displayed directly at the SAW, either on an adjacent screen, projected onto a working surface or made available to the operative through augmented reality. This would have a number of benefits:

- Reduction in errors associated with out of date drawings or other information - the operative would have access to the latest information (and only the latest) when it is needed;
- Reduced time lag between design and assembly - changes could be made up until the last instant and still displayed at the SAW;
- Ability to mass customise - sub-assemblies such as services risers or ceiling cassettes could be highly customised in terms of e.g. type, density and positioning of MEP components as long as the components themselves and their method of installation are standardised (this is one way in which platforms could achieve the 'bespoke solution / standard process' square in the matrix on page 13).

Bottom: Guided instruction used in the assembly of GlaxoSmithKline's 'Factory in a Box' platform

Guided instruction in particular allows highly efficient mass customisation. Each platform can have specific inclusions or exclusions; these processes are simple to implement and can be dynamically controlled.

Of course, the flow of information relating to SAWs would be two way. The processes taking place at SAWs would be creating data (reported back via operatives themselves, cameras or RFID tags within materials or components) relating to:

- Number of tasks completed, components installed etc.;
- Time taken to complete each task;
- Quality issues or non-conformances detected.

This would create feedback loops which would inform future best practice (communicated back via SOPs) e.g. if a particular task is taking longer than anticipated then a better solution can be found through design or root cause analysis.

Again, the opportunity for continual improvement through data capture and analysis is another of the ways in which manufacturing has consistently driven higher rates of productivity.

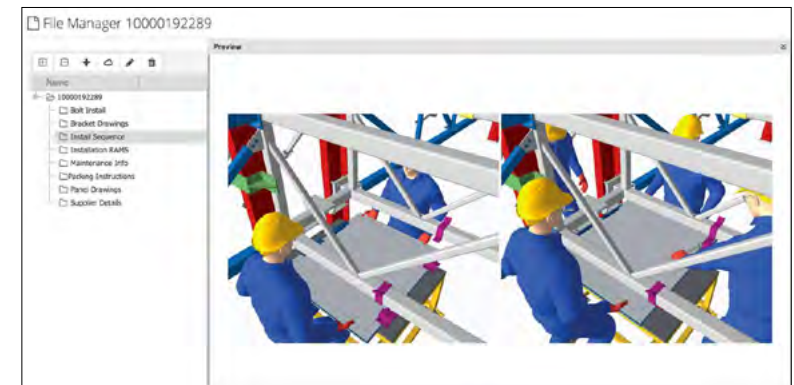

Materials

SAWs would be an extremely effective way of leveraging just in time (JIT) methods which have been well understood and adopted in the manufacturing sectors. This is certainly one of the areas where organisations such as the MTC will be able to provide a wealth of knowledge to accelerate adoption.

The intention in developing the SAWs to date has been to use relatively raw or commoditised materials, to limit the number of times materials are processed on the way to their final point of use (in line with the 'test for platform efficiency'). The impact of this can be seen in the Platform 2 case study where the majority of components in the super structure require little or no fabrication.

The Sub Assembly case study shows how commoditised materials are turned into a high performing facade within relatively few steps.

These two case studies demonstrate that, since platforms are inherently digitally enabled, it is easy to create highly accurate information including bills of materials. These can be used to:

- Accurately plan and control material movement, facilitating initiatives such as JIT;
- Minimise waste in all its forms (including over production, unnecessary inventory and unnecessary handling and transportation);
- Use of poka-yoke assembly techniques - each component will normally only fit one way, avoiding errors and reducing levels of supervision required.



SAWs as a unit of manufacturing 'currency'

By combining the data relating to all of these, SAWs could become a unit for measuring manufacturing capability and capacity. For instance:

- The labour market could be analysed in terms of numbers of operatives trained in particular SAWs;
- The capacity of manufacturing facilities could be assessed in terms of numbers and types of SAWs;
- The two could be linked by 'conversion rates' once there is sufficient data to establish the output per SAW type per operative;
- It would then be possible to e.g. match the labour market with known manufacturing capability, and foresee the need to increase one or the other;
- Work could be moved to wherever the most appropriate capacity of space and labour exists;
- Major programmes could be assessed in terms of requirements for SAWs, and using the conversion rates above a ready calculation of numbers of operatives, numbers of SAWs etc. could be quickly established;
- Once this model becomes sufficiently mature it could be the starting point for a new marketplace, matching labour, demand and capacity anywhere in the UK (and beyond);
- This would help ensure a steady pipeline of work for individual facilities, and facilitate an aggregated view of manufacturing capacity - see 'Factory + workforce sharing' in section 2.

Which SAWs have been tested so far?

The next section gives a detailed description of each of the SAWs referenced above:

- Cassette manufacture to avoid working at height;
- 3D manipulation to aid assembly;
- Bring the worker to the point of assembly of a large item;
- Linear processes.

In the first instance these will appear relatively manual and 'low tech'; this is deliberate.

Highly advanced manufacturing sectors such as aerospace and automotive have spent decades developing the capabilities and infrastructure that allow them to harness the benefits of automation and advanced manufacturing techniques. However, the first industrialised, mass production techniques were still relatively simple and labour intensive and it has taken time and considerable investment for the manufacturing sector to evolve.

Rather than try and 'short circuit' this process, it is proposed that mastering this initial set of simple manufacturing processes is a necessary precursor to developing a properly industrialised construction industry.

Developing platforms that can maximise the use of SAWs will encourage rigour and discipline in the design process, and enable key foundational skills to be understood and developed.

It is hoped that this initial list of 'SAWs' will, in time, extend to include automation, additive manufacture and other sophisticated techniques.

However, by starting with the basic set of manufacturing processes any increase in sophistication can take place in response to and at a pace that is entirely dictated by the uptake of platforms and the size of the pipeline of projects using them.

If the uptake is rapid and the pipeline expands quickly, then this will justify the investment needed to automate. The graph on the right shows how unit costs drop with increase in numbers of units (typically referred to as economies of scale); numbers of units need to be very large before automation starts to become viable.

In the meantime, the SAWs shown here have some significant advantages:

- Minimal set up cost, lowering the barriers to their adoption and maximising the number and type of facilities that could host them;
- Familiarity of the tools and techniques used, making them readily adoptable by the existing workforce (and requiring minimal training before new operatives are able to be productive);
- Maximum adaptability for rapid evolution in response to lessons learnt and as the market for platforms matures.

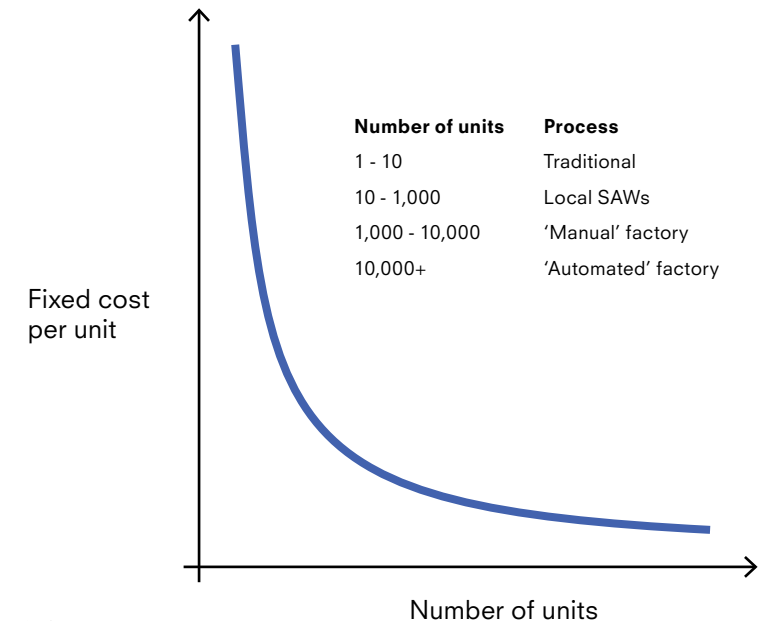

Fixed costs per unit drop as unit numbers increase

Cassette manufacture

While the use of MEP services modules is increasingly common, on many projects there remains a significant amount of soffit-mounted MEP distribution installed traditionally. This poses a number of issues:

- Unnecessary work at height; statistics published by the Health and Safety Executive show that in construction, 49% of fatal injuries over the last 5 years are the result of falls from height, as are 18% of non-fatal injuries.*
- A highly unproductive work face - working above head height after first creating the necessary clearance zones, ensuring the correct lifting equipment is available etc. all limit the amount of useful work that can be done in a given period;
- Extensive overlapping of the trades doing this work exacerbates these difficult conditions;
- Creation of multiple zones within the ceiling void for ductwork, pipework, cable trays, lighting etc. increases the overall volume of the asset (and therefore of air that needs heating and treating) and the area of the envelope.

The creation of highly coordinated ceiling cassettes, combining structural, architectural and MEP elements compressed into a single assembly would have some significant benefits:

- Significant reduction in work at height;
- Better quality installation due to assembly on a workbench;
- Overall depth and volume of asset reduced;
- On site installation time dramatically reduced by lifting multiple elements in a single operation;
- These could be readily mass customised using standard components and processes.

The images on the right show a prototype cassette for testing:

- Manufacturing execution system (MES);
- Digital QA;
- Gantry robot assisted assembly.

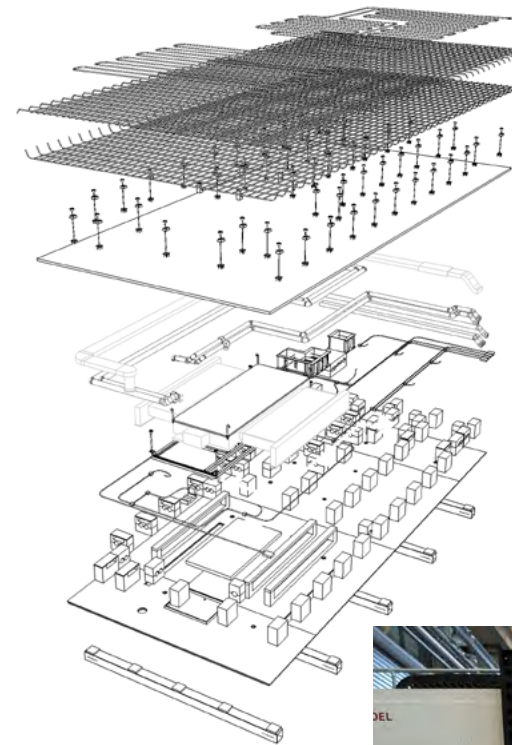

Top: Ceiling cassette model

Bottom: Prototype ceiling cassette at MTC

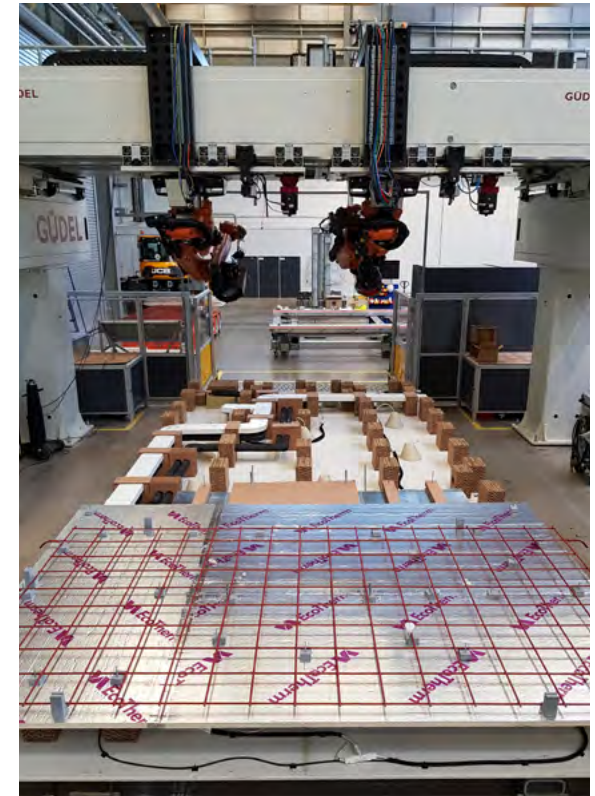

* <http://www.hse.gov.uk/statistics/industry/construction/>

3D manipulation to aid assembly

The Health and Safety Executive annually publishes statistics on work-related musculoskeletal disorders; an estimated 8.9 million working days were lost due to these in 2016/17. In construction, they account for 65% of work-related ill health.*

As a result there is a significant opportunity to increase safety, productivity and overall job satisfaction through the careful ergonomic design of work stations, considering:

- Person + working height;
- Range of reach;
- Range of vision;
- Presentation of parts, tools and materials;
- Lighting;
- User adjustment of work station.

One of the techniques that has been used in automotive manufacture to create safer, less strenuous working conditions is to 'bring the work to the worker' by physically manipulating the zone to be worked on so it is ideally placed for easy access.

The technology required for accurate lifting, manipulation and positioning of even the heaviest objects is an advanced and mature marketplace. The needs of this SAW can therefore already be met using known technology, and there is a well established market place of providers who could quickly accelerate its adoption.

The riser example shown here is relatively straightforward, but allows two operatives to work on separate halves of the assembly such that each has easy access to their point of assembly (which is a flat surface at a comfortable height).

Once the two halves are complete they can be brought together for the installation of the final components.

This arrangement prevents the operatives from having to reach into the riser itself to install components, which would be difficult and, over time, strenuous. In addition the riser can be highly compressed in area while still building in maintenance and replacement access for those elements that require it.

* www.hse.gov.uk/statistics/causdis/musculoskeletal/msd.pdf



Top: Initial riser components are installed on two separate benches.

Middle: One of the benches is then mechanically tipped up by 90° and attached to the other.

Bottom: Final components are then installed.

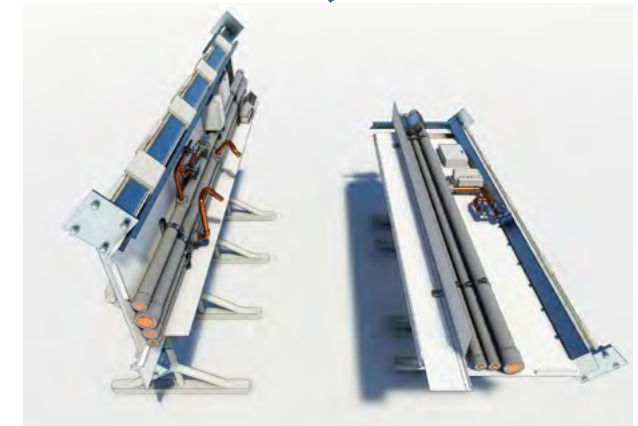

Prototype riser



Bring the worker to the assembly

Some elements are simply too heavy, cumbersome or fragile to be manipulated (or to do so would introduce stresses that the element will not experience in its final position; over-engineering the element to accommodate these would introduce unnecessary cost and so should be avoided).

As a result, there will be instances where the worker will need to be safely placed at the point of work. However, as with the 3D manipulation SAW, the technology required is well established and can be readily adopted.

The example here shows a car lifting platform, modified for the purposes of stacking Superblocks (see sub assembly case study).



Modified car lifting jack, used to create a safe working platform for operatives stacking Superblocks - see Sub Assembly case study

Linear processes

Sub assemblies such as the ceiling cassette lend themselves to remaining static whilst a series of tasks & activities are performed on and around them to assemble components.

Linear SAWs could also be referred to as progressive assembly and would typically be deployed where a series of sequential operations enable materials to go through a pre-determined process. Raw materials undergo a series of treatments to create and refine components prior to said components being deployed as part of a platform.

Henry Ford first introduced the principle of moving products past work stations (linear SAWs) to reduce assembly time and at the same time increase quality. It was this specialisation in singular tasks which led to the separating of processes and tasks, allowing Ford to de-skill and by default de-risk his processes.

Raw materials for the production process are positioned along the linear SAW where each operative has a continuous flow of product to perform his or her tasks. The specialist and repetitive nature of each step/task allows for optimal ergonomics around the operative such as minimal material lifting and handling, consistent working height, vertical or gravity assisted assembly, and more robust and fixed jigs to improve quality assurance.

The schematic on the opposite page has been produced through collaboration between Bryden Wood and the MTC to show the typical nature of a linear SAW.

This process eliminates a lot of double handling as raw materials are delivered to the point of use/production and continue along the linear SAW ever closer to the point of finished form as a product where it is either stored or shipped. Linear SAWs facilitate specialisation of labour and capital where the mass production delivers high productivity and lower cost per unit in a controlled environment as opposed to site based.

Another feature of linear SAWs is that they enable the creation of uniform product. This significantly reduces the risk associated with variation or, as it is described in the construction industry, tolerance stack or creep.

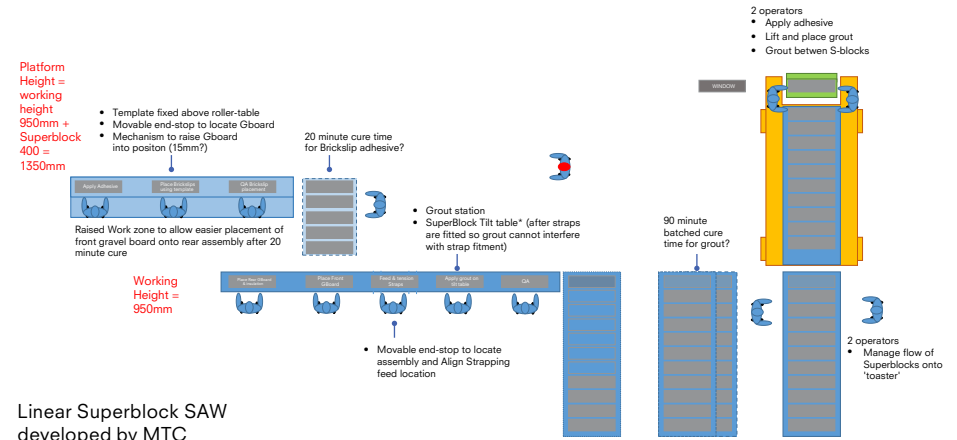

Visualisation of linear Superblock SAW developed by MTC

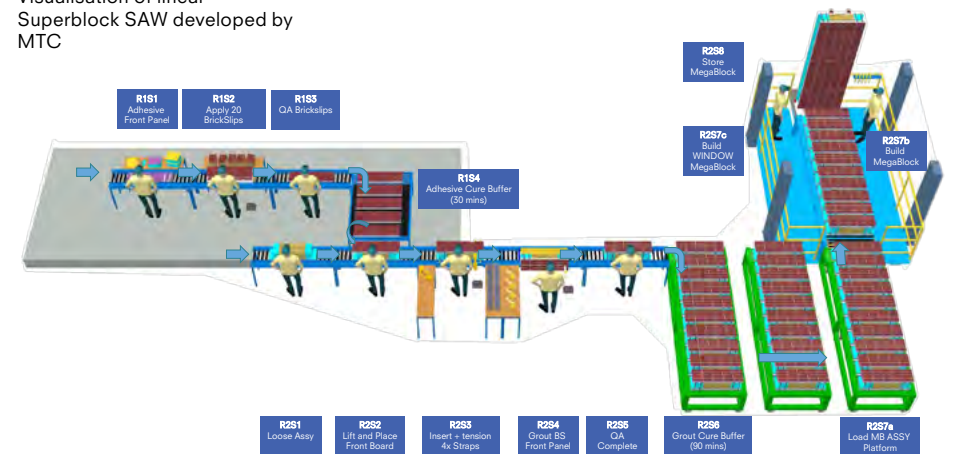

Platform case study:
Platform 2



What is Platform 2?

This section provides more detail on one of the key platforms, 'Platform 2' (see diagram, right). Key considerations and cost drivers for the selection of construction methodologies & building types are:

- Function (sector & building height);
- Form (site conditions and complexity);
- Location (logistics and access);
- Programme (risk and procurement route).

Platform 2 has been designed to suit a wide range of variability within each of these criteria. 'Delivery Platforms for Government Assets' described this as 'a highly flexible and versatile system that would be highly customisable but with the following characteristic 'upper limits':

- Spanning capability up to 11m;
- Variable structural loading capacity (depending on span) up to 5kN/m²;
- Storey height up to 4m;
- Building height up to 14 storeys;
- Ability to work with a range of levels of interior fit out / mechanical and electrical services etc.'

It can be seen from the diagram opposite that this platform is applicable to a number of different building types and, previously noted, creating a platform wide applicability is a good way to ensure a pipeline of demand. This section will outline:

- How the design of Platform 2 meets the 'test of efficiency' defined earlier in this document;
- How Platform 2 compares to traditional forms of construction (in terms of capital cost).

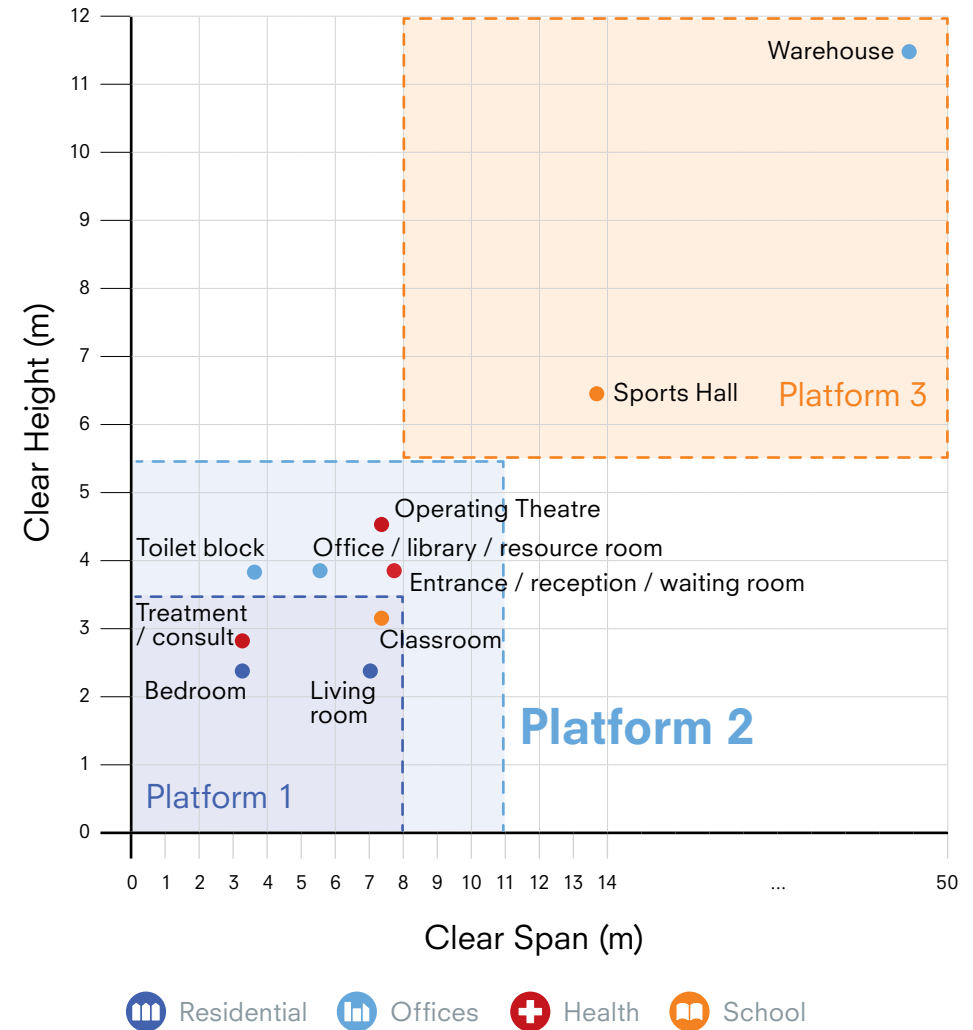

Levels of fabrication

One of the principles that has been used in developing the platforms so far is to use basic materials with the minimum amount of fabrication where possible.

The diagrams on the right show the levels of fabrication in the Platform 2 superstructure. It can be seen that the majority of components use no fabrication, very low or low levels of fabrication (these can be thought of as 'dumb' components). These components tend to be the large, heavy, commoditised elements including:

- Columns - standard square hollow sections are used with no 'fabrication' as such (a single hole is punched or laser cut in each column);
- Beams are made using a standard rolled metal profile (metal coils are passed through a highly efficient, automated rolling process with virtually no waste, no double handling etc.)

As much 'intelligence' as possible is then placed in the interfaces (e.g. bracketry which is self locating to control tolerances and is colour coded to ensure correct application etc.) The 'intelligent' components are small, manually handleable and accurately mass produced.

The level of bespoke production is thus focussed on far less tonnage than designs for e.g. traditional steel composite or flat slab solutions.

This has significant cost implications - rather than passing the steel through multiple fabrication processes (and incurring significant labour, factory overhead and transportation costs) the residual asset value is very high since the conversion cost is very low.

In the assembly phase, the use of low fabricated elements and connecting brackets removes the need for skilled trades - rather than requiring specialist steel erectors, the frame can be bolted together by trained, competent operatives (this has been demonstrated in the prototyping phase).

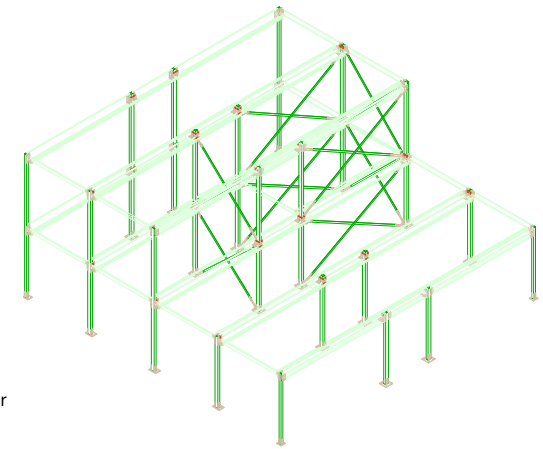

Elements with no fabrication or very low level of fabrication

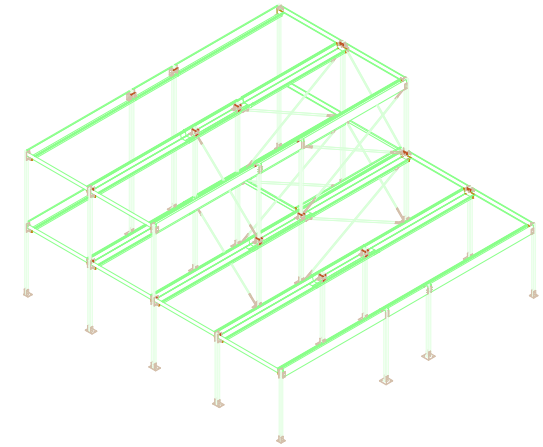

Elements with low level of fabrication (bolted connections to elements)

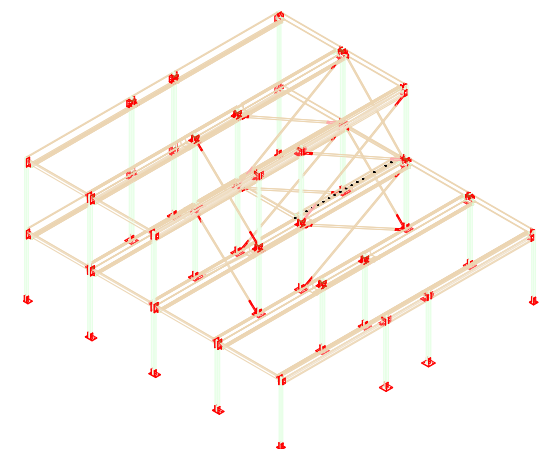

High level of fabrication (welding and voids with bespoke production)

Intelligent, accurate interfaces

The diagram below shows the bracketry required for the sample section. It should be noted that regardless of the size of the facility constructed using Platform 2, there are only:

- 8 types of column brackets;
- 10 types of baseplate brackets for all conditions
- 12 types of bracing brackets

These are fabricated in large numbers to very high degrees of accuracy. One of the automated outputs from the model is a colour coded diagram as below, together with a parts count. The actual brackets could be colour coded to ensure correct application.

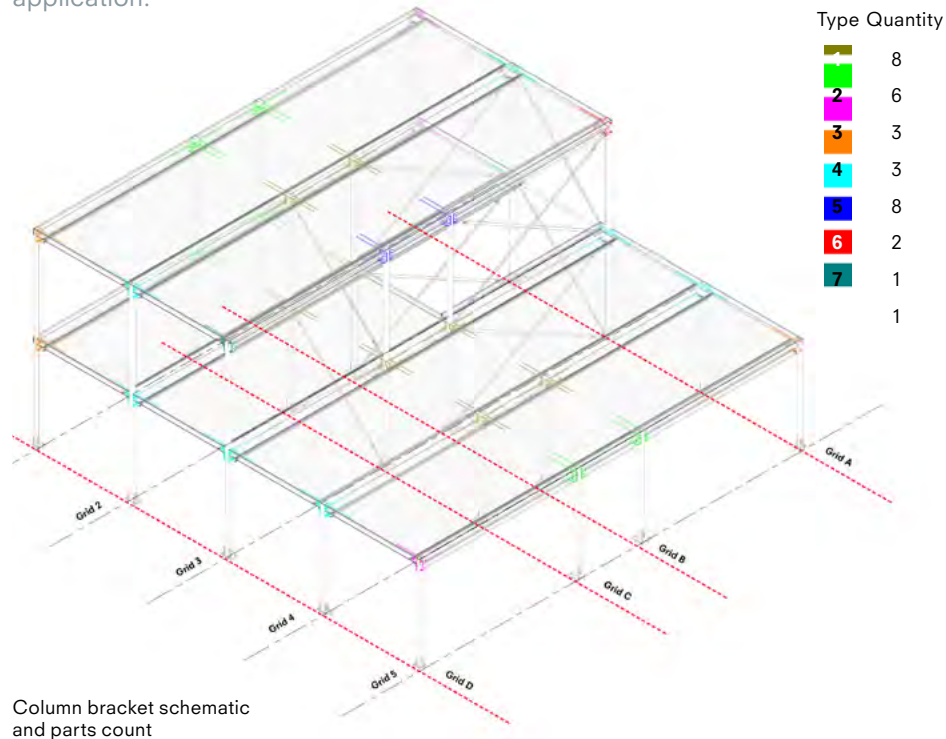

Column bracket schematic and parts count

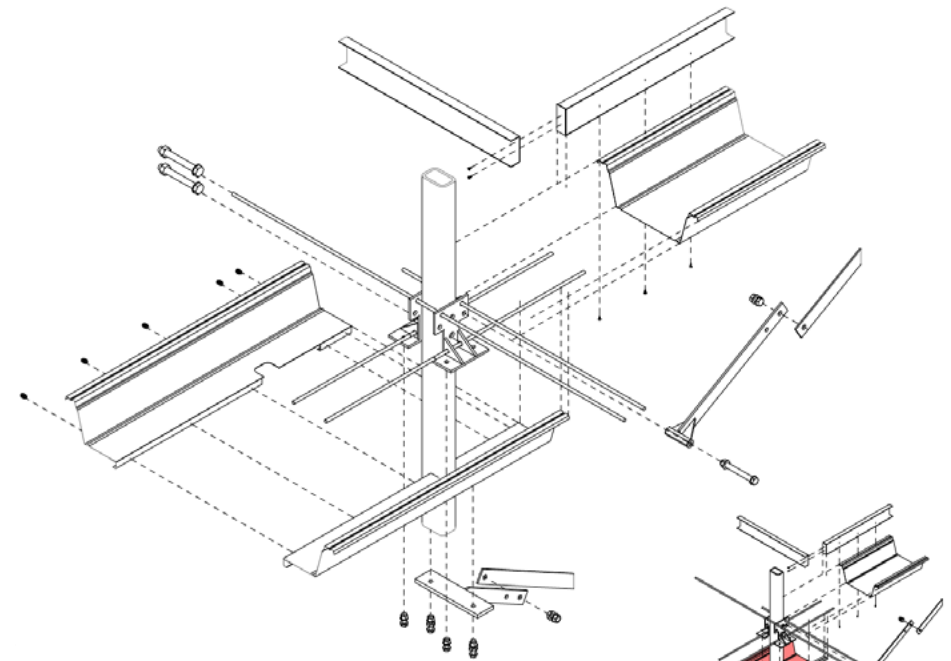

Installation sequence

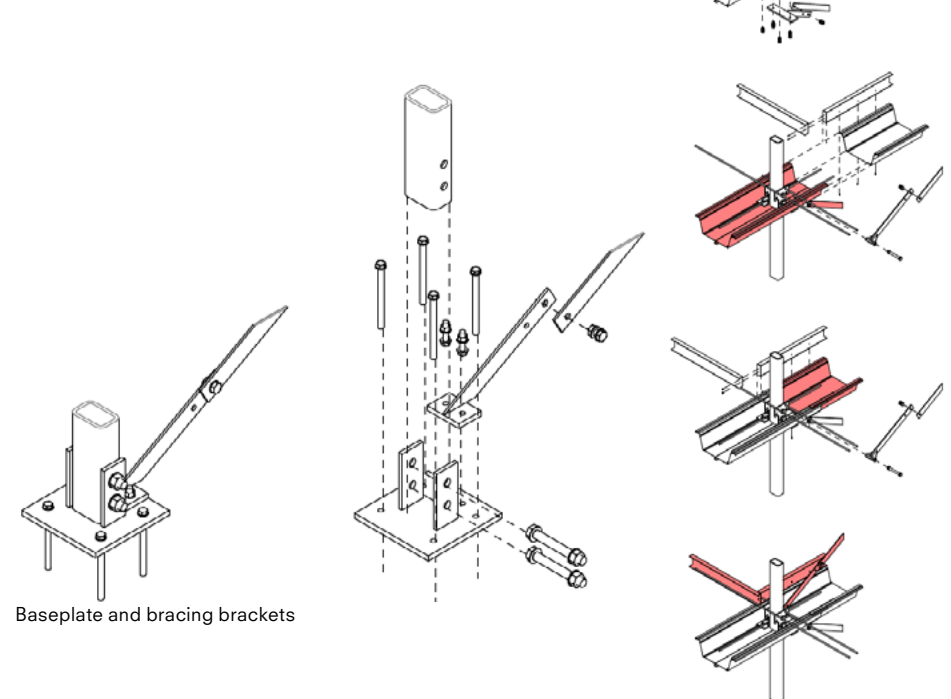

Baseplate and bracing brackets

Weight of components

In addition to requiring little or no fabrication, the components in Platform 2 have been designed to be as light as possible; the mass in the building comes in the form of in-situ pumped concrete. There are a number of reasons for this:

- The steel components can be transported extremely effectively with regard to logistics - the number of components that can be brought in a single vehicle movement represent a much higher 'volume' of building than for a traditional steel frame;
- Components can, for the most part, be handled safely by one or two operatives without the need for large lifting plant. This reduces preliminaries costs and increases the productivity of operatives on site;
- Combined with the low levels of fabrication described previously, this amplifies the cost savings since the overall tonnage of steel is low.

Using in situ pumped concrete is potentially counter-intuitive, since generally off site techniques seek to eliminate wet trades. However, even pre-cast planks require grouting together or have a topping layer. If it is accepted that there will be some wet trades on site, pumping concrete actually has some benefits:

- Accurate, re-usable shutters form part of the platform, creating pre-cast levels of quality from an on-site activity; Transporting wet concrete (or batching on site) is effective from a logistics point of view - transporting large pre-cast elements is in many cases less effective;
- The main mass of the building can be pumped into position, not craned. This reduces the need for heavy lifting equipment;
- A large area of in-situ concrete can be pumped in a single, tightly controlled operation, so it can be highly productive work;
- The in-situ ties all of the elements together to create a contiguous structure which is advantageous in terms of fire and acoustic performance.

Components colour graded by weight - darker is heavier.

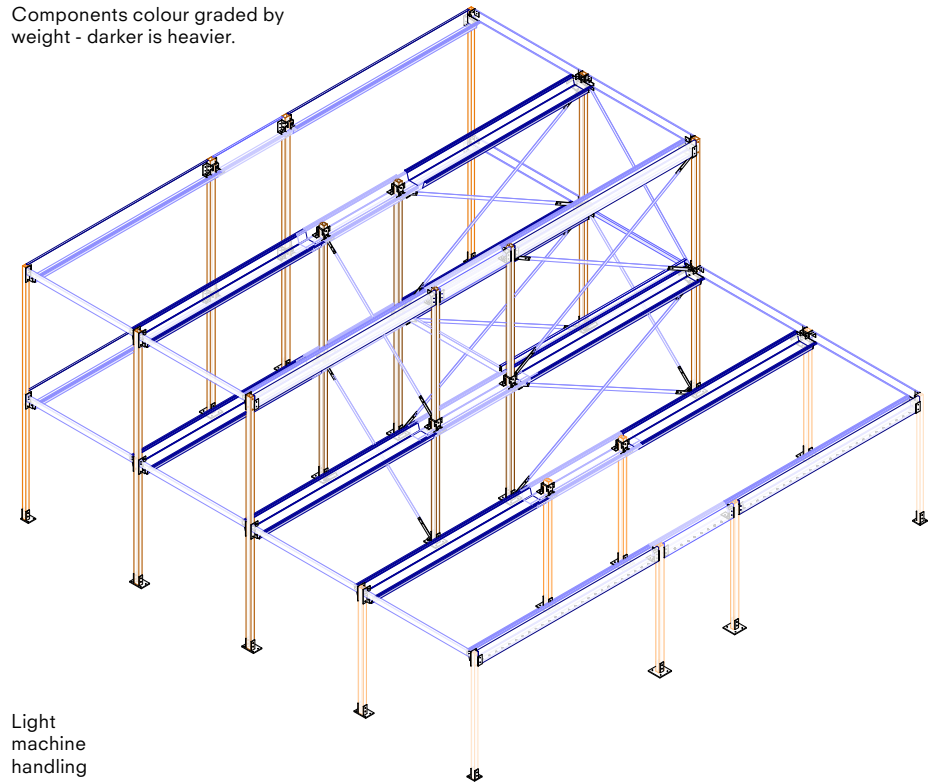

Light machine handling



1 or 2 person lift

STEEL BEAM SCHEDULE BY WEIGHT					
Count	Type	Total Length (m)	Nominal Weight (Kg/m)	Weight per Beam Type (kg)	Comments
6	U386x50x100x3	5425	13.55	74	Edge beam parallel to Comflor 210
2	U386x50x100x3	5450	13.55	74	Edge beam parallel to Comflor 210
8	Full	5235	10.00	52	Comflor 210 metal deck
2	U150x58x58x3	5565	6.39	36	Staircase additional steel
1	RHS100x50x5	2760	10.80	30	Staircase edge beam perpendicular to Comflor 210
1	U386x50x100x3	2125	13.55	29	Edge beam parallel to Comflor 210
3	U386x50x100x3	2075	13.55	28	Edge beam parallel to Comflor 210
3	50x75Cut1	5510	5.00	28	Comflor 210 metal deck cut
3	50x75Cut2	5510	5.00	28	Comflor 210 metal deck cut
1	75x50Cut1	5510	5.00	28	Comflor 210 metal deck cut
1	75x50Cut2	5510	5.00	28	Comflor 210 metal deck cut
6	L170x110x30x3	3225	8.25	27	Edge beam perpendicular to Comflor 210
5	L170x110x30x3	3200	8.25	26	Edge beam perpendicular to Comflor 210
2	8x75	5115	4.80	25	Bracing
2	8x75	5135	4.80	25	Bracing
2	8x75	4955	4.80	24	Bracing
2	8x75	4880	4.80	23	Bracing
2	8x75	4460	4.80	21	Bracing
2	8x75	3895	4.80	19	Bracing
1	U150x58x58x3	2830	6.39	18	Staircase additional steel
8	75x100CentralCut	3300	5.00	17	Central half Comflor 210 metal deck cut
2	8x75	3525	4.80	17	Bracing
2	8x75	3625	4.80	17	Bracing
3	50x75CentralCut	2250	5.00	11	Central half Comflor 210 metal deck cut
1	75x50CentralCut	2250	5.00	11	Central half Comflor 210 metal deck cut
8	U40x40x20x3	1400	2.40	3	Central half Comflor 210 connection
16	U40x40x20x3	200	2.40	0	Central half Comflor 210 connection
95					

Schedule of steel beams by weight - note the vast majority can be manually handled by 1 or 2 people

Typical installation sequence

This is the installation sequence for the components used to create the images, tables and costs in this section.

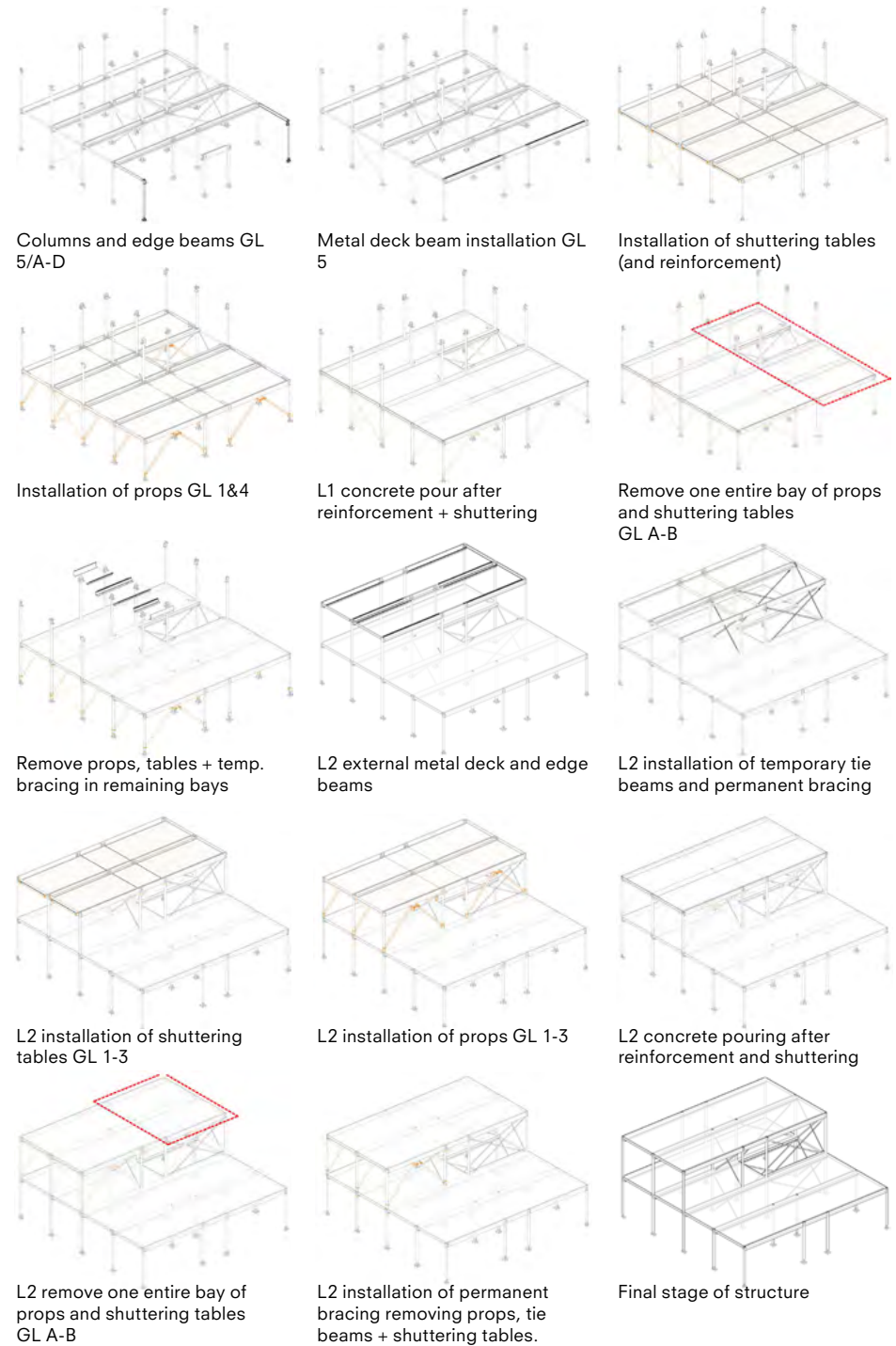
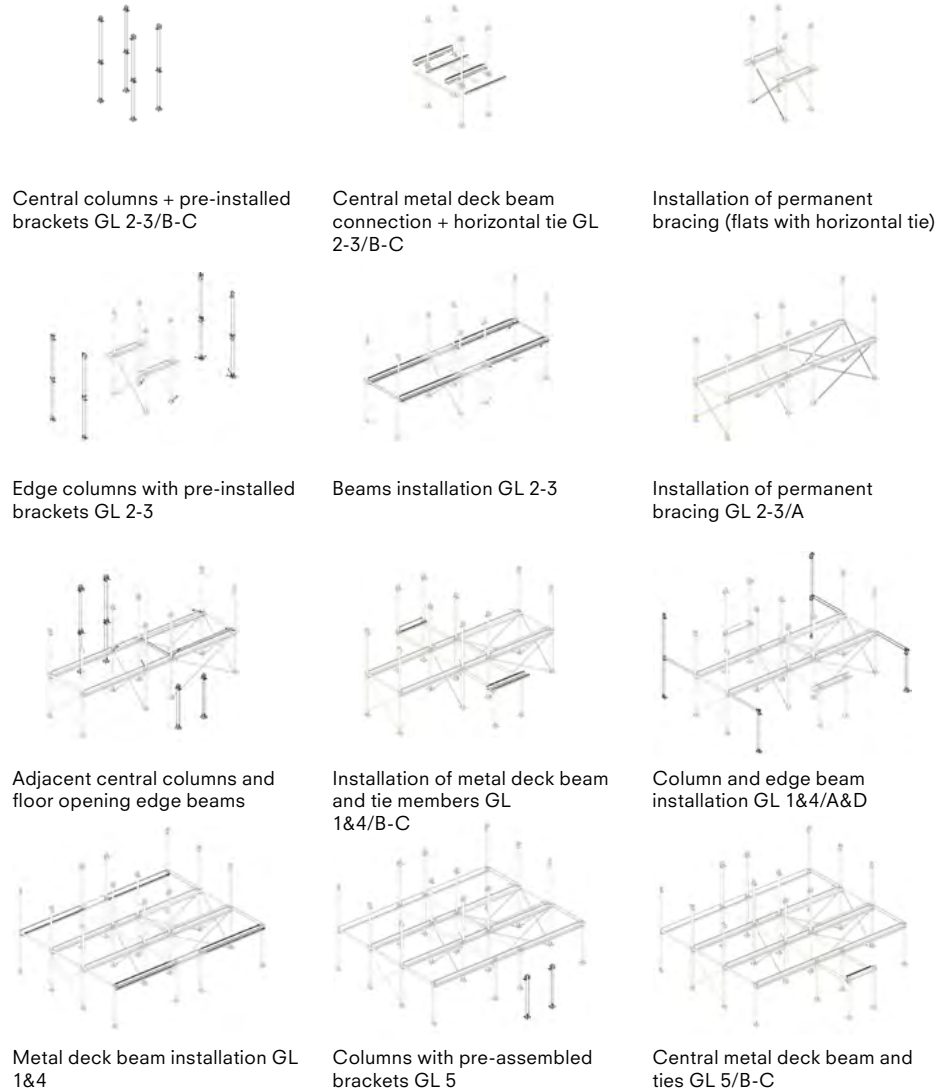

Benchmarking

It is often assumed that a frame with the minimum tonnage will also have the lowest cost. However, as the figure below shows, the raw material cost typically accounts for only 30-40% of the total frame cost, with fabrication costs also accounting for 30-40%. For more complex frame designs, with higher proportions of non-standard sections and complex or specialist systems with higher fabrication requirements, the overall rate per tonne is likely to be higher than for a standard frame.

The construction of the steel frame typically accounts for around 10-15% of the total frame cost. It is therefore necessary to consider whether there are features of the proposed building that would significantly affect the erection cost as this will see a corresponding impact on the total cost of the frame. The extent of repetition, piece count, type of connections to be used and access can all have a significant impact on the cost of constructing the frame.

For the purposes of benchmarking a 'triage' process was carried out to identify which elements should be included in the comparison i.e. where the use of a Platform creates the most benefit. The table opposite sets out the three categories to be considered.

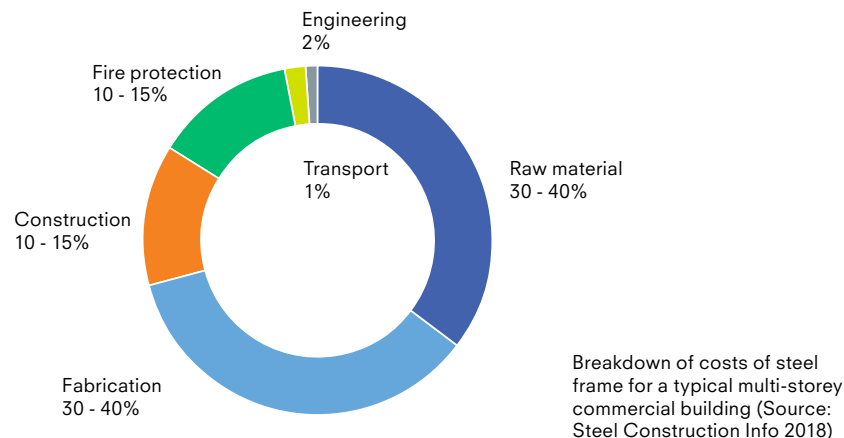

Elements where the use of platforms or products is transformational	Must include
Elements where the use of platforms or products is not transformational but is beneficial	Could include
Elements where the industry norm is either adequately developed, complementary or likely to reduce risk	Exclude

To create a detailed costs analysis, a representative section of a platform-based solution was analysed - in this case the sample was:

- 13.5m x 13.4m;
- L01 is the full plan dimension but with a penetration;
- L02 is only half the plan area.

Drawings and a model view are included on the pages that follow. The same section was then designed and modelled for a number of construction types:

- Flat slab concrete;
- Steel frame with concrete slab;
- Platform 2.

This allowed a direct comparison to be made for the superstructure elements.

Flat slab concrete

	No.	Unit	Rate	Sub total	Totals	per m ²
Concrete					£ 11,256	£ 41.57
Concrete in Upper Floor slabs	74.46	m ³	£ 130.00	£ 9,680		
Finish Surface of concrete	270.75	m ²	£ 2.00	£ 542		
Concrete in Columns	5.75	m ³	£ 180.00	£ 1,035		
Reinforcement					£ 10,165	£ 37.54
Fabric Reinforcement A252	270.75	m ²	£ 4.68	£ 1,267.11		
Fabric Reinforcement A395	270.75	m ²	£ 6.30	£ 1,705.73		
Laps of fabric reinforcement as 20%	270.75	m ²	£ 2.20	£ 594.57		
Loose Bar Slab, inclusive of punching shear links	4.70	tonnes	£ 1,100.00	£ 5,172.92		
10mm Bars in columns	0.19	tonnes	£ 1,550.00	£ 294.50		
20mm Bars in columns	1.13	tonnes	£ 1,000.00	£ 1,130.00		
Formwork					£ 11,793	£ 43.55
Soffits of slabs	270.75	m ²	£ 20.00	£ 5,415		
Columns	74.72	m ²	£ 50.00	£ 3,736		
Edges of slabs 275mm high	105.66	m ²	£ 25.00	£ 2,642		
Construction cost sub total					£ 33,214	£ 122.67
Preliminaries			25%	£ 8,303		£ 30.67
Overheads and Profit			10%	£ 4,152		£ 15.33
Total to summary					£45,669	
Cost per m² GIFA					£ 168.67	

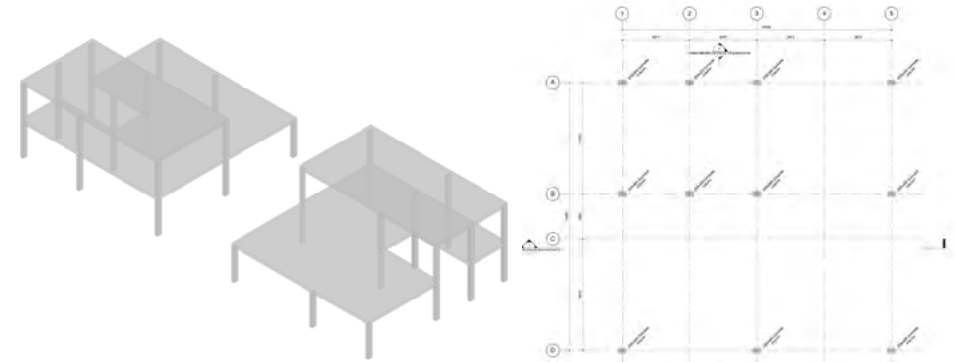

L0 general arrangement

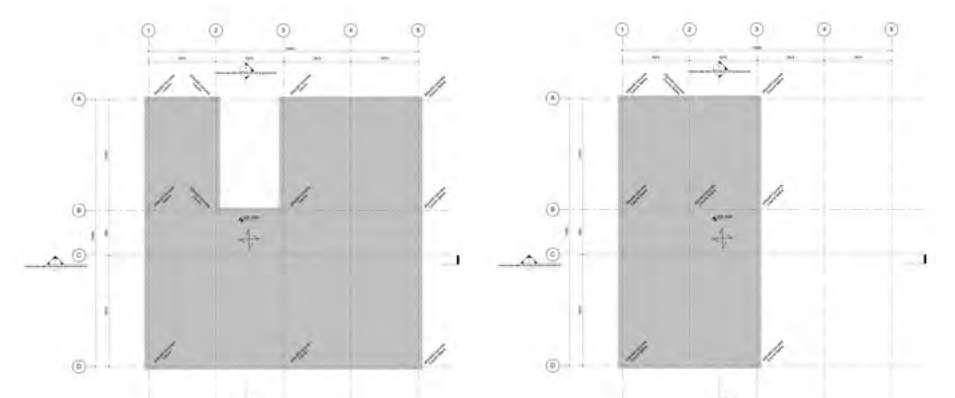

L01 general arrangement

L02 general arrangement

Programme notes:

Procurement 7 weeks for form work / reinforcement

Installation 3 weeks

RC FLAT SLAB OPTION - CONCRETE COLUMN SCHEDULE					
Count	Type	Volume (m ³)	Total Length (m)	Reinforcement/Volume (kg/m ³)	Reinforcement (kg)
19	250x400	5.75	57	175.00	1005.81
19		5.75	57		1005.81

RC FLAT SLAB OPTION - FLOOR SCHEDULE					
Count	Comments	Area (m ²)	Volume (m ³)	Reinforcement/Volume (kg/m ³)	Reinforcement (kg)
2	250mm RC Flat Slab	270.75	74.46	100.00	7445.54
2		270.75	74.46		7445.54

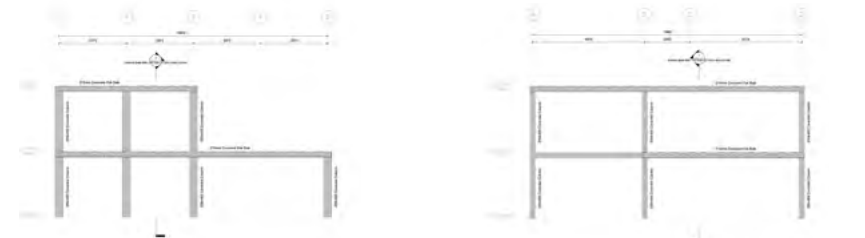

Longitudinal section

Transverse section

Steel composite slab

	No.	Unit	Rate	Sub total	Totals	per m ²
Concrete					£ 4,585	£ 16.93
Concrete in Upper Floor slabs	31.10	m ³	£ 130.00	£ 4,043		
Finish Surface of concrete	270.75	m ²	£ 2.00	£ 542		
Reinforcement					£ 1,300	£ 4.80
Fabric Reinforcement A193	270.75	m ²	£ 4.00	£ 1,083		
Laps and Perimeter U-bars - estimate as 20% of above line mesh weight	270.75	m ²	£ 0.80	£ 217		
Decking					£ 7,000	£ 25.85
Conflor 60 1.2 gauge	270.75	m ²	£ 20.00	£ 5,415		
Shutter Edges of slabs 150mm high	105.66	m	£ 15.00	£ 1,585		
Steelwork					£ 32,049	£ 118.37
10x 100 Bracing	0.544	tonnes	£ 1,800.00	£ 979		
Beam UB 203x133x25	0.085	tonnes	£ 1,800.00	£ 153		
Beam UC 203x203x46	3.084	tonnes	£ 1,500.00	£ 4,626		
Beam UC 203x203x52	6.519	tonnes	£ 1,500.00	£ 9,779		
Beam UC 203x203x100	3.362	tonnes	£ 1,500.00	£ 5,043		
Column UC 152x152x30	0.284	tonnes	£ 1,500.00	£ 426		
Column UC 203x203x46	2.379	tonnes	£ 1,500.00	£ 3,569		
Allowance for Fittings/ Connections	1.626	tonnes	£ 2,100.00	£ 3,414		
Fire Protection allowance	270.75	m ²	£ 15.00	£ 4,061		
Construction cost sub total					£ 44,933	
Preliminaries			23%	£ 10,335	£ 38.17	
Overheads and Profit			10%	£5,527	£ 20.41	
Total to summary					£ 60,795	
Cost per m² GIFA					£ 224.54	

Programme notes:

Procurement 14 weeks for steelwork / decking

Installation 2 weeks

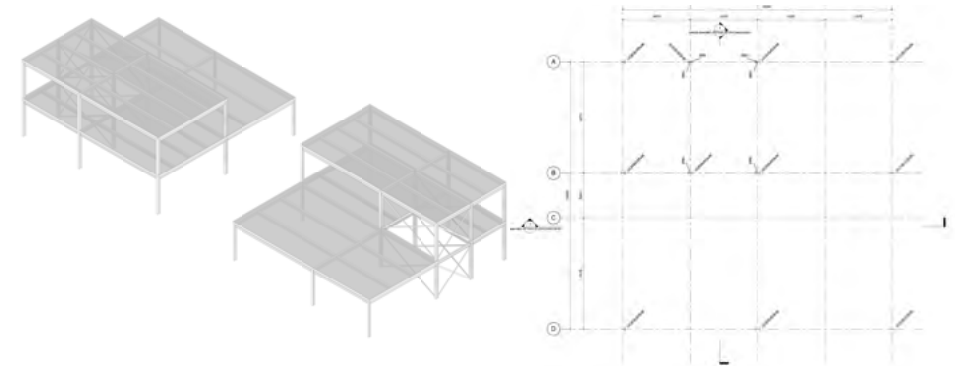

L0 general arrangement

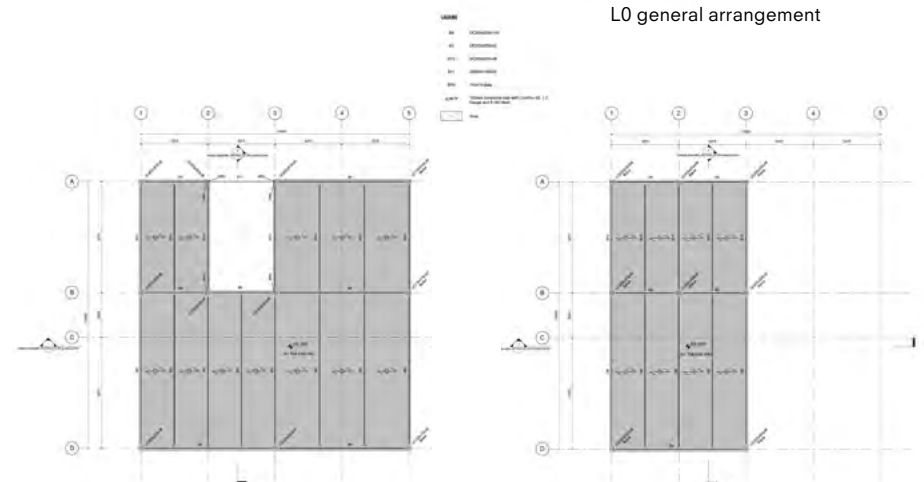

L01 general arrangement

L02 general arrangement

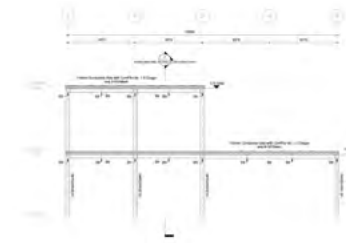

Longitudinal section

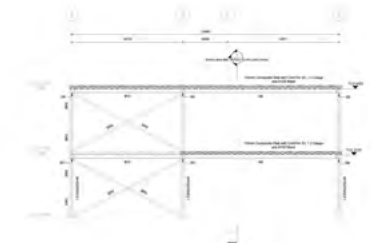

Transverse section

Platform 2

	No.	Unit	Rate	Sub total	Totals	per m ²
Concrete					£ 7,562	£ 27.93
Concrete in Upper Floor slabs	54.00	m ³	£ 130.00	£ 7,020		
Finish Surface of concrete	270.75	m ²	£ 2.00	£ 542		
Reinforcement					£ 4,928	£ 18.20
Floor reinforcement	4.48	tonnes	£ 1,100.00	£ 4,928		
Decking					£ 5,686	£ 21.00
Platform Shuttering	270.75	m ²	£ 21.00	£ 5,686		
Edges of slabs included in steelwork	105.66	m	£ -	£ -		
Steelwork					£ 12,385	£ 45.74
RHS/ SHS Steelwork	3.8	tonnes	£ 1,250.00	£ 4,750		
Connections allowance on heavy steel	0.38	tonnes	£ 4,000.00	£ 1,520		
Conflor cuts / lightweight	2.33	tonnes	£ 1,500.00	£ 3,495		
Baseplates	20	no.	£ 25.00	£ 500		
Column Brackets	30	no.	£ 25.00	£ 750		
End Plates	18	no.	£ 10.00	£ 180		
Windpost Plates	53	no.	£ 10.00	£ 530		
Auxilliary plates	66	no.	£ 10.00	£ 660		
Nuts/ bolts etc		included				
Construction cost sub total					£ 30,560	
Preliminaries			20%	£ 6,112		£ 22.57
Overheads and Profit			10%	£ 3,667		£ 13.54
Total to summary					£40,340	
Cost per m² GIFA					£ 148.99	

Programme notes:

Procurement 8 weeks for steelwork / decking

Installation 2 weeks

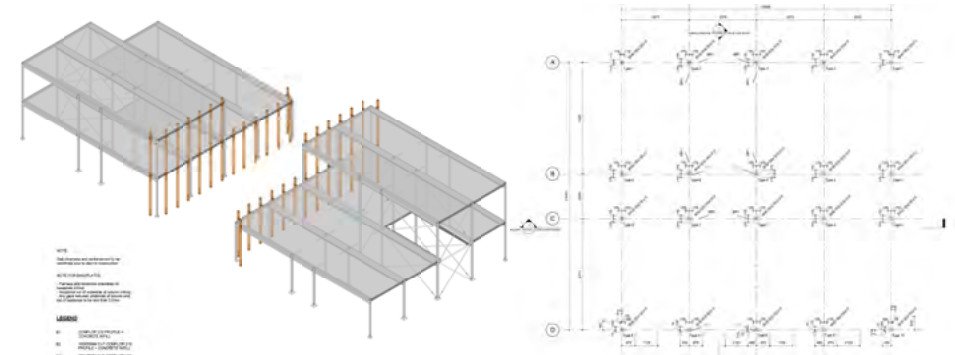

L0 general arrangement

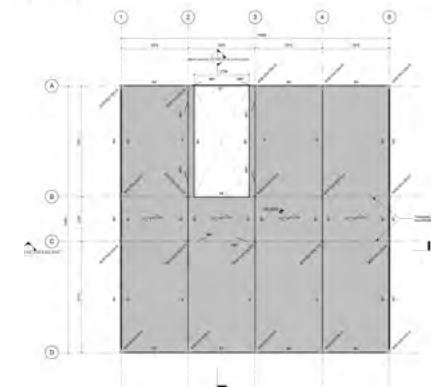

L01 general arrangement

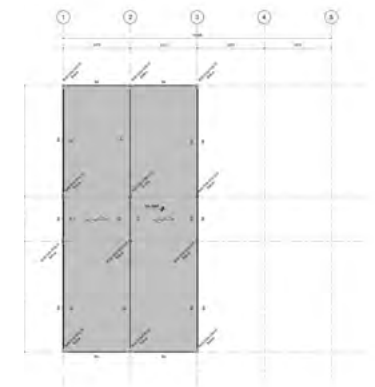

L02 general arrangement

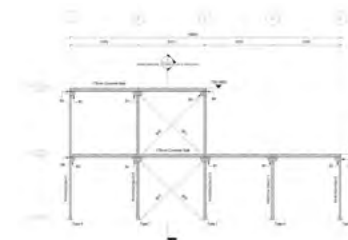

Longitudinal section

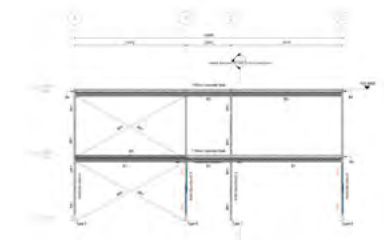

Transverse section

Summary

The table on the right summarises the outcome of the preliminary benchmarking - Platform 2 is round 12% cheaper than flat slab concrete, and around 34% cheaper than composite slab steel frame.

While this represents a significant saving should be noted that the superstructure only accounts for a portion of the overall building cost.

However, a platform 2 superstructure would enable a range of additional benefits that flat slab construction does not, for instance providing a highly accurate frame that will facilitate the use of other platform components (façades, MEP, fit out) which will continue to amplify the time and cost benefits;

In addition use of Platform 2 would facilitate the other initiatives set out in this book relating to overall UK manufacturing capability, diversifying the skill workforce, continual improvement etc.

	Flat slab concrete frame £/m ² GIFA	Composite slab steel frame £/m ² GIFA	Platform 2 £/m ² GIFA
Concrete	£ 41.57	£ 16.93	£ 27.93
Reinforcement	£ 37.54	£ 4.80	£ 18.20
Formwork / Deck	£ 43.55	£ 25.85	£ 21.00
Steelwork	£ -	£ 118.37	£ 45.74
Construction Cost Sub Total	£ 122.67	£ 165.96	£ 112.87
Preliminaries	£ 30.67	£ 38.17	£ 22.57
Overheads and Profit	£ 15.33	£ 20.41	£ 13.54
Cost per m² GIFA	£ 168.67	£ 224.54	£ 148.99
Programme			
Procurement (weeks)	7	14	8
Construction (weeks)	3	2	2
	10	16	10

Sub assembly case study:
'Superblocks'



What are Superblocks?

Superblocks have been developed as a low cost, high performing facade element that is suitable for a number of asset types including domestic, education, health care and commercial.

In line with the 'test of platform efficiency' Superblocks use materials that are low cost and highly commoditised (see the description of materials used, opposite) and handled the fewest number of times by low skilled but highly competent operatives.

The manufacturing steps for making individual Superblocks are very simple, and a finished Superblock is manually handleable. These are then stacked 10 high (using a modified car jack) to create units referred to as 'Megablocks' which can be transported to site using a modified ISO shipping container to optimise transportation and logistics before being lifted into their final position.

The image below shows the very first prototype Superblock, made in August 2017. Since then the design has been considerably refined through further prototyping and testing. Note the images here all show a brick finish, although any type of brick or any other final finish could equally be applied.

This section describes:

- The manufacture process for Superblocks and Megablocks;
- An analysis of labour content;
- Transport + logistics;
- Physical testing and performance.



First prototype Superblock from August 2017.

1. Gravel board - this is a highly commoditised product that can be sourced from a very wide supply chain at low cost. As this component is needed in very large quantities the precise design of the gravel board can be optimised and tested to ensure a suitable level of robustness, while being as light as possible to facilitate manual handling and increase productivity and safety in manufacture.
2. Brick slips - any colour and finish may be used. This will allow a range of architectural aesthetics to be developed in terms of colour, pattern etc., which could assist in distinguishing building function and differentiating between house blocks.
3. This void allows the creation of a 200 x 200mm reinforced concrete wind post between facade panels - the shape allows phenolic insulation to pass behind the wind post, preventing cold bridging.
4. Extruded phenolic insulation.
5. Mineral wool insulation - dropped into Superblock and allowed to expand between the gravel boards to ensure a tight fit with no air gaps.
6. Stainless steel spacers prevent Superblock from reducing in thickness over time. They also enable accurate location of Superblocks together.
7. Perforated stainless steel band strap - this holds the Superblock together. This piece of band strap will pass through the concrete wind post that is formed between facade panels - the perforations allow the concrete to bond securely to the strap.
8. Stainless steel band strap - this holds the Superblock together.

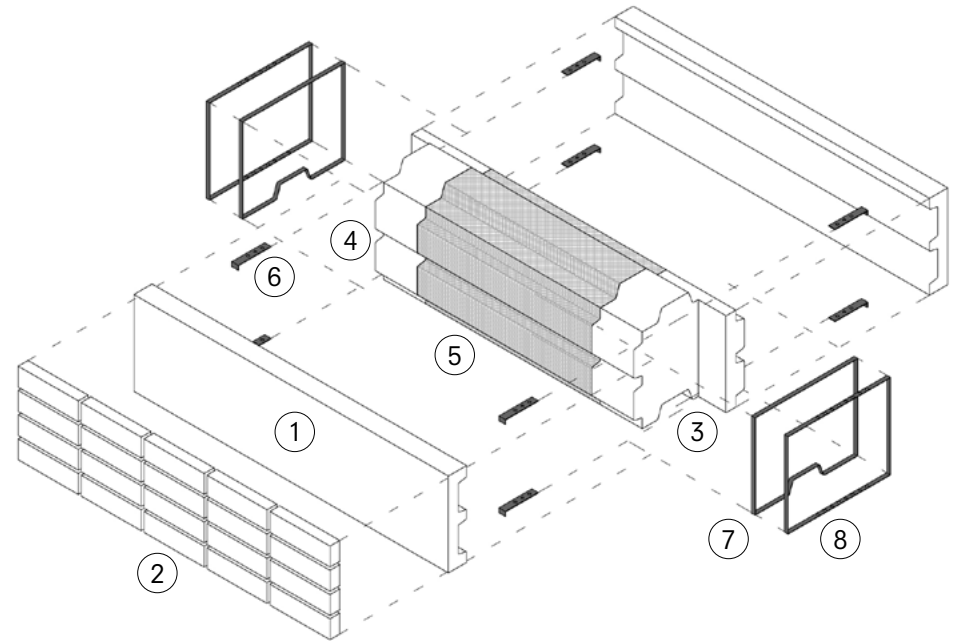

2. Brick slips - any colour and finish may be used. This will allow a range of architectural aesthetics to be developed in terms of colour, pattern etc., which could assist in distinguishing building function and differentiating between house blocks.
3. This void allows the creation of a 200 x 200mm reinforced concrete wind post between facade panels - the shape allows phenolic insulation to pass behind the wind post, preventing cold bridging.
4. Extruded phenolic insulation.
5. Mineral wool insulation - dropped into Superblock and allowed to expand between the gravel boards to ensure a tight fit with no air gaps.
6. Stainless steel spacers prevent Superblock from reducing in thickness over time. They also enable accurate location of Superblocks together.
7. Perforated stainless steel band strap - this holds the Superblock together. This piece of band strap will pass through the concrete wind post that is formed between facade panels - the perforations allow the concrete to bond securely to the strap.
8. Stainless steel band strap - this holds the Superblock together.

Superblock manufacture using SAWs

The section on SAWs explained the principles of highly productive, competent labour and the use of standard operating procedures or guided instructions.

These are discrete tasks which can be refined, optimised, documented and taught in such a way that they can be deployed at scale by upskilled, trained operatives.

A traditional construction site has low productivity since a large number of the tasks undertaken are subject to their own 'micro' logistics, planning and execution.

A highly efficient site would have operatives carrying out a range of highly planned, productive routines, each pre-planned within the overall assembly programme.

Across the programme of Government investment there will be a vast number of individual activities. However, the scale and nature of the investment means that, as with the design of the components themselves, the creation of standardised processes should be subject to the same degree of rationalisation, standardisation and optimisation. In design terms, this approach will be used to minimise the cost of the components and ensure that they are fit for purpose while being produced at scale. In manufacturing terms, productive routines will be used to minimise labour cost while ensuring that the manufacture and assembly can be carried out completely safely and with the same level of quality and consistency.

A useful analogy for this may be scaffolding installation, whereby reasonably bespoke structures are rapidly assembled by (typically) low skilled but trained operatives. They are able to do this by using standard routines for unloading and lifting the components, using standard connection details etc.

It is important to think of standardised processes as an essential part of the component design, fabrication and assembly - the value of the component design will be lessened if the labour content is not given the same level of scrutiny. SAWs, then, are a way of enshrining productive working through a series of physical components. For platforms, each component can be considered to have three 'versions' of itself. These are:

- The physical component / assembly;
- The 'digital twin' which is used for data analysis, procurement, logistics etc.;
- The standardised processes related to a component which capture every aspect of its manufacture, transport, aggregation with other components to form sub assemblies, assembly on site, ongoing maintenance and ultimately dis-assembly.

To demonstrate the idea of standardised processes, this next section will track the manufacture of a Superblock panel from its components through creation of a Megablock to site assembly as a facade panel.

It will be seen that the pace of the various activities has a continuous link from component level through to the overall site approach.

Manufacturing processes

Process 1 - Brick slip panel manufacture (on or near site, in workshop)

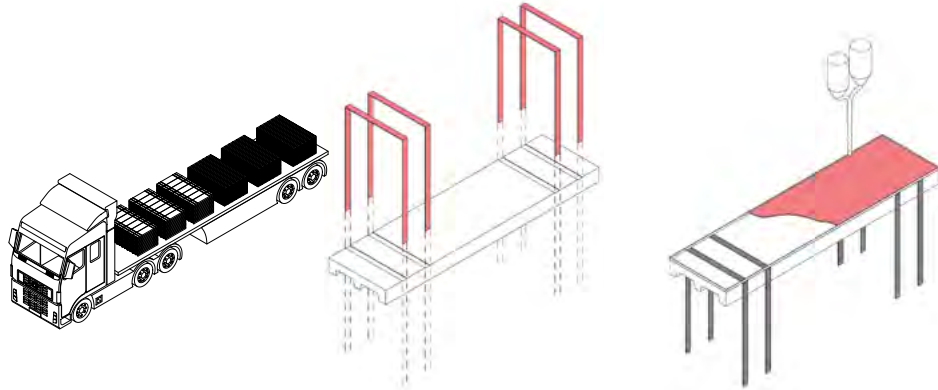

Loose brick slips delivered
Loose gravel boards delivered

Stainless steel band straps are loosely fitted.

Part 1 of plastic former placed on gravel board. Two part glue mixed and applied. Levelled to top of former.

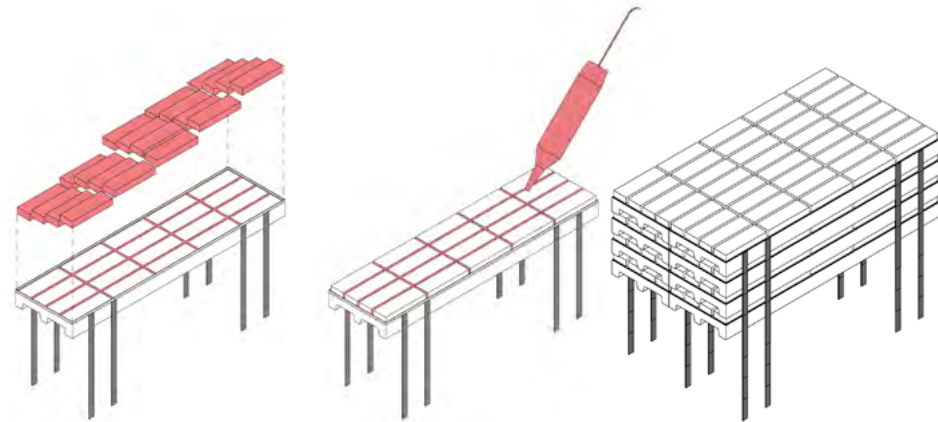

Part 2 of plastic former placed on top and slips placed into grids (4 slips tall, 5 slips long i.e. 20 slips per panel).

Boards and slips pressed together in correct location. Slip grout lines are filled with mortar.

Completed boards stored in racks to cure. Once cured, boards are moved to 'Super block' manufacturing line - see Productive Routine 2 below

Process 2 - Super block manufacture (on or near site, in workshop)

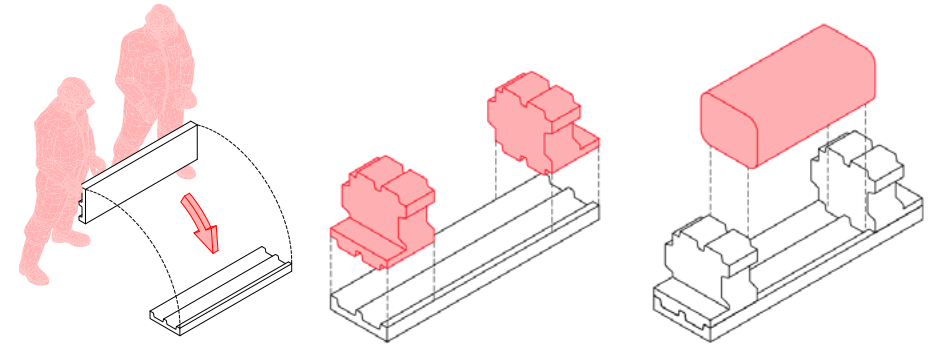

Gravel board laid on its back on production table

Rigid preformed phenolic insulation added

Flexible mineral wool insulation installed bagged to be cut just before assembly

Sub assembly sequence for brick slip panel production shown on the left

Special tool used to automatically tighten + secure bands

Completed block stored dry, then moved to assembly platform when needed. Weight is approximately 45kg.

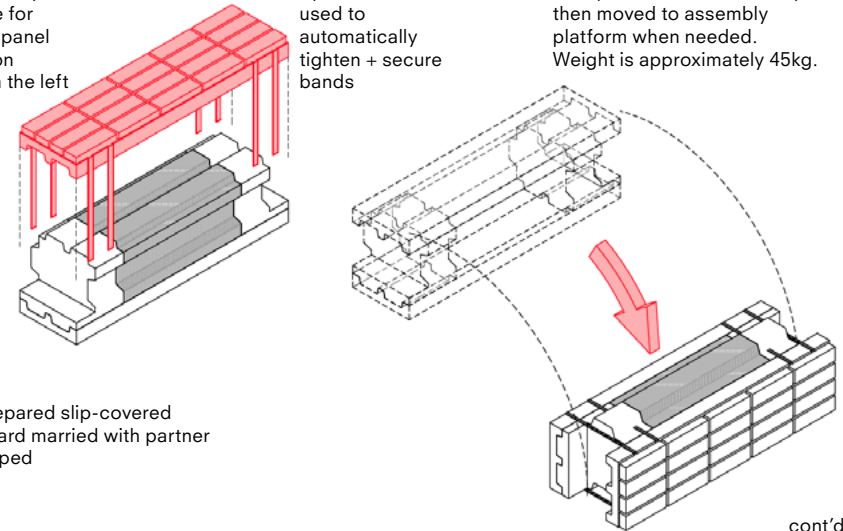

Ready prepared slip-covered gravel board married with partner and strapped

Manufacturing processes cont'd

Below + right: Superblock
SAWs



Above: Brick slips being applied to gravel boards



Above: The Megablock lifting platform



Right: A stack of completed Superblocks

Manufacturing processes cont'd

Process 3 - Megablock manufacture (either on site, close to point of use or in a permanent or temporary factory)

A lifting platform arrives on site in a shipping container with removable top structure which is lifted off once the platform is in place. It is moved around the building as the facade installation progresses. The photo on the right shows the actual lifting platform used to make Megablocks.

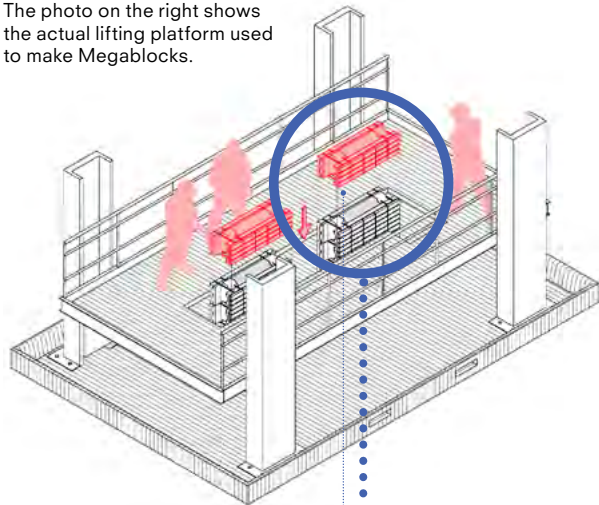

Shaped slot to allow assembly of corner blocks. Folding 'trap door' covers this when standard blocks are being assembled.

Pre-cast indentation to locate clip below

Thin coat adhesive / grout applied

4 special stainless steel clips inserted behind slip line. They are multi-purpose:

- Locate blocks laterally;
- Provide a spacer to control gap between blocks and to match grout lines;
- When concrete wind posts are cast, provide a solid tie between gravel boards and concrete core.

Mortar applied between blocks to match slip joints (undertaken when secured to building from mobile platform)

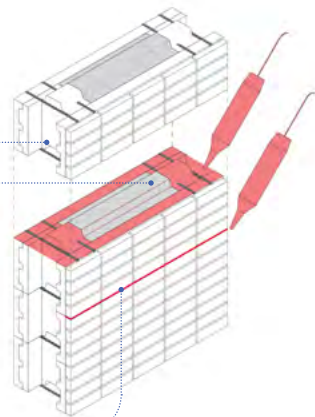

Process 4 - Megablock installation (on site at point of use)

Stack of 10 blocks creates 1 storey. These are picked up with a special frame.



When dried horizontal and vertical mortar lines between blocks are filled to match slip lines.

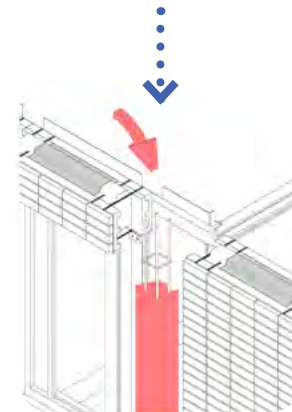

Blocks are fixed back to perimeter steels. Also rebar cage inserted into void between blocks, which is then filled with concrete.

- | | |
|--|------------|
| Apply thin coat adhesive / grout; | 4 minutes |
| Lower block into position and locate accurately; | 5 minutes |
| Tie block back; | 5 minutes |
| Fill with concrete; | 10 minutes |
| Vibrate | 5 minutes |

Labour, skills + competencies











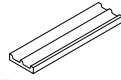

As described above, Superblocks are designed to be assembled by turning a low skilled workforce into competent operatives. The figures here are based on some of the initial batches of Superblocks - it is expected that the rates will continue increasing.



The current assembly time for a Superblock is just over 3 minutes, using the mix of labour outlined here. The colours below are used throughout to show skill levels associated with particular tasks.



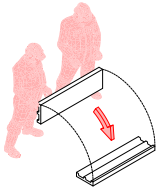

It will be seen that a high percentage of the work can be carried out by operatives with no prior training or construction experience. This, coupled with the relatively low time and cost for setting up SAWs in an existing facility suggest that it will be possible (if it would be beneficial to the project) to create highly productive, temporary facilities close to a site, thereby:

- Creating employment and skills training for a diverse, local workforce;
- Minimising travel distances, and therefore carbon emissions and stress on existing infrastructure;
- Maximising the beneficial impact of investment in assets by engaging local SMEs in the delivery phase.

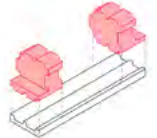
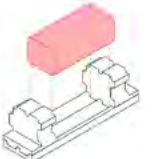
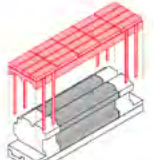
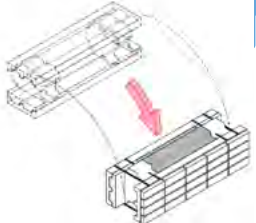

Activity	Team size	Rate + limiting factor	Supervision	Efficiency + Output
 Feeding boards 2 minutes		240 / day		Note The first two activities will take place for the 1/4 of a day and then, after the daily required stock of banded boards is reached, they will help in the rest of the activities that require more time and are limiting the final output.
 Banding boards 2 minutes		240 / day		
 Glueing 5 minutes		480 / day		80% efficiency 192 / day 960 / week
 Slip placement 10 minutes		240 / day		Note In order to decrease the impact of the two 5 minutes activities to the overall output as much as possible, they take place across three workstations, one operating for 8 hours and the other two for 6 hours (by the operatives doing the first two activities).
 Grouting 10 minutes		240 / day		
 Stacking 2 minutes		240 / day		

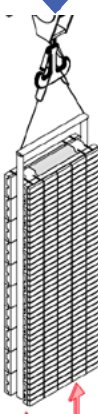
Activity	Team size	Rate + limiting factor	Supervision	Efficiency + Output
 Placing board 1 minute	2	107 / day / team		2 teams 80% efficiency 171 / day 856 / week
 Phenolic insulation 2 minutes	2			
 Mineral wool insulation 2 minutes	2			
 Banding block 8 minutes	2			
 Stacking complete blocks 2 minutes	1			

Activity	Team size	Rate + limiting factor	Efficiency + Output
 ↓			
 ↓	3	8 / day / team	4 teams 80% efficiency 26 / day 128 / week
 ↓	3		
 ↓	3		
 Stacking_ glueing blocks 1 hour			

Note
MTC have developed a dolly system that allows drying Megablocks to be removed from the toaster increasing throughput to 18 / day.

Activity

Team size

Rate + limiting factor

Efficiency + Output

Labour content summary

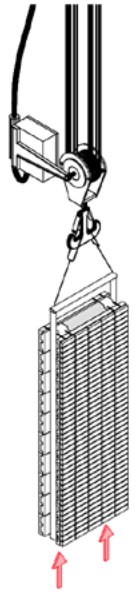

15 / day / team

**2 teams
80% efficiency
24 / day
120 / week**

Installing facade panels
(Site concrete team fill windposts)

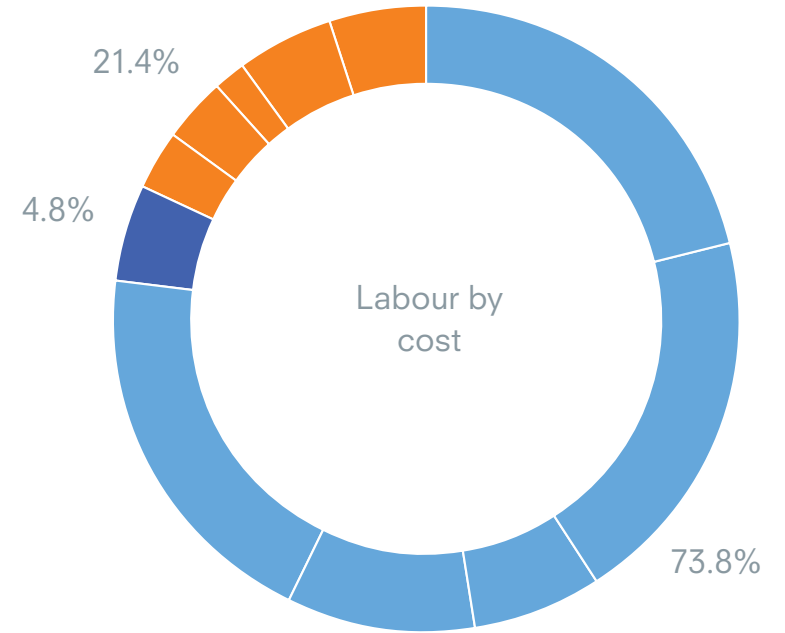
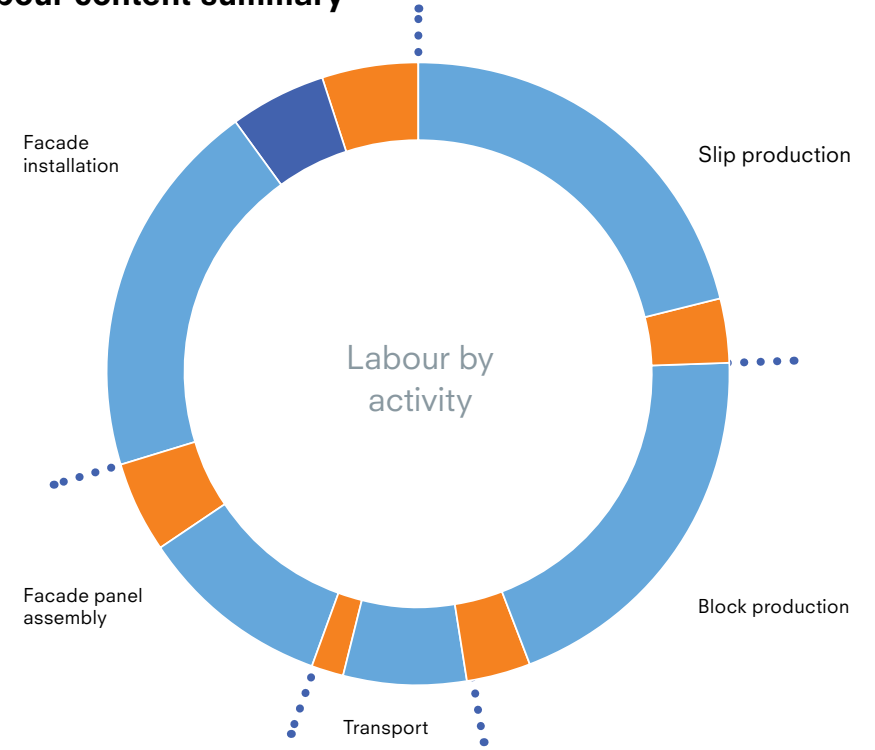

Transport + logistics

* Source: WRAP

† Refer to WRAP guidance document 'Using Construction Consolidation Centres' to reduce construction waste and carbon emissions

Most of the elements of the 'test for platform efficiency' have now been discussed, the final one being logistically controlled delivery to site.

The impacts of waste in construction are well known - Waste Resources Action Plan (WRAP) estimates that of 400 million tonnes of construction material used each year, 100 tonnes ends up as waste, with 25 tonnes going direct to landfill.* There are therefore huge cost as well as environmental benefits in reducing waste in all its forms.

Superblocks have been designed to be logistically highly efficient, maximising the area of facade that can be moved in a single vehicle movement or crane lift.

The images on the right show a 'Cakeboxx' shipping container (standard-sized container that allows the top to be lifted off rather than using doors) which is currently in manufacture and has been developed especially to transport Megablocks. Obviously this will allow transportation to make use of the existing infrastructure based around shipping containers (discussed elsewhere in this document).

- Each container can carry 24 Megablocks, the equivalent in area to 81m² in a single crane movement;
- A single vehicle movement can transport 162m²;
- At a storey height of 3m that is 54 linear metres of facade.

WRAP estimates that use of a Construction Consolidation Centre (of the type proposed by the Heathrow Expansion Programme) alone can result in:

- A reduction in freight traffic to site by up to 70%;
- Increased productivity of site labour by 30 minutes per day leading to a 6% productivity gain;†

Building transportation efficiency into the design of platform components will therefore make them well placed to sit within an increasingly efficient construction logistics network.

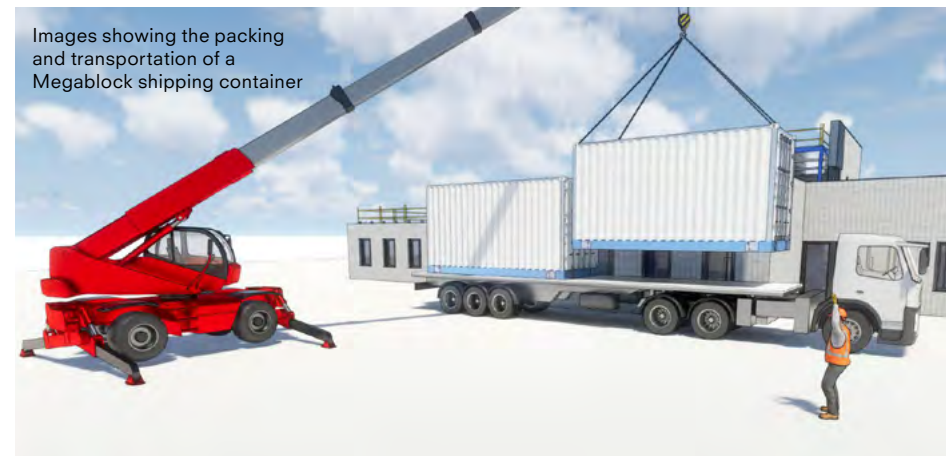
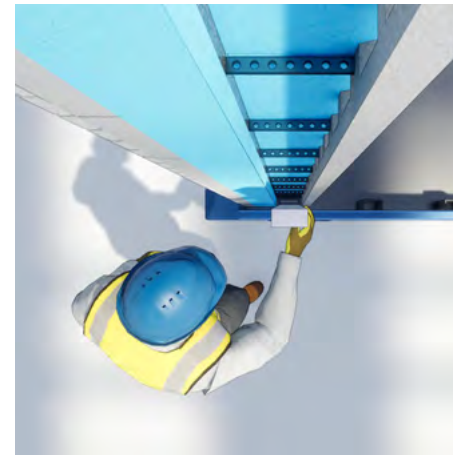
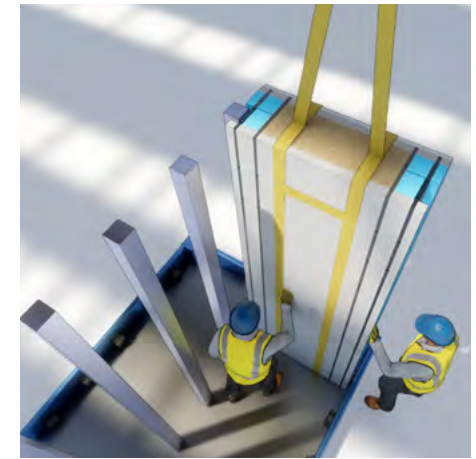

Testing + certification

With any new and innovative building system a series of tests need to be undertaken, not only to ensure they are fit for purpose, but also to allow warranties to be granted during the construction phase.

The Superblocks have been subjected to a series of initial tests based on robustness and weather resistance:

- An impact test was conducted to CWCT standards replicating blows to the façade from weights and sharp implements.
- The test sample also passed the CWCT spray bar test, which replicates a 100 year storm event. A camera inserted inside the blocks showed no water ingress.

Having successfully concluded the initial tests, external tests have been commissioned with the Building Research Establishment (BRE). The BRE are currently undertaking a full suite of certified tests covering:

- Structural integrity;
- Fire;
- Acoustics;
- Thermal performance + air tightness;
- Freeze thaw / thermal shock;
- Negative pressure water ingress;
- Wind loading.
- Grab test;

The successful completion of this full testing programme will give designers and constructors the confidence to specify the 'Superblock' façade system on a wide range of projects in the future.

Section 2

Potential impact



Transformational change created
by existing open platforms



How shipping containers shaped the global economy

Statistics and dates taken from 'The Box: How the Shipping Container Made the World Smaller and the World Economy Bigger'
Marc Levinson, first published 2006

Prior to the invention of the ISO shipping container by Malcolm McLean in 1955, it was calculated that freight accounted for up to 25% of the cost of some commodities. The prohibitive cost of freight meant that manufacturers, for the most part, produced and sold their goods locally.

A large part of this cost was in the unproductive multiple handling of goods as they were unpacked and repacked between trucks, trains, ships, warehouses and docksides (a comparison could be drawn with the way materials are often handled on construction sites).

The creation of a multi-modal container had immediate and dramatic impacts; in 1956, loading the first ship to use McLean's design was calculated to cost 15.8 cents per imperial ton, at a time when the cost of loading loose cargo onto a comparable sized cargo ship was \$5.83 per imperial ton; an 97% saving.

Since then the container has become the central component in a highly effective system that spans the globe. While the box itself is relatively simple it is surrounded by a complex infrastructure, specifically designed to move containers around the world as efficiently as possible and powered by digital controls, precise automation and highly coordinated logistics.

The growth of global shipping and the impact it would have on the world economy were unforeseen, and occurred primarily because the container was made available as an external platform. In 1963 McLean released to industry the patents to the corner fitting that locks containers together; he recognised that making this technology widely available would grow the overall market for containerisation and amplify the benefits, which is precisely what happened. Once ports and transport companies could confidently work to a standard, they were able to commit the investment needed to rapidly expand their capability. This in turn encouraged others to adopt the platform in one of the best examples of a powerful network effect.

An early example of containerisation shaping the global economy occurred towards the end of the 1960s. The US military first used containerisation to supply the war in Vietnam. By stopping off in Japan to fill the boxes on the return leg, there was suddenly a viable way of rapidly upscaling Japan's nascent export of consumer electronics and other goods. The Japan-West coast route, which had no container ships serving it before September 1967, was served by 7 different companies by the end of 1968.

This prompted an unprecedented shift; Japanese seaborne exports rose from 27.1 million tonnes in 1967 to 40.6 million tonnes in 1969, the first full year of services to California. Japanese exports to the US leaped 21% in 1969 alone.

Simply put, globalisation as we know it would not have been possible without the invention of the shipping container and the industry's adoption of a standardised, platform-based approach. Prior to this, the inefficiency of handling and long delays it incurred, made transportation too unpredictable for manufacturers to risk suppliers being able to provide goods and materials on time. As a result they would hold large buffer stocks of inventory to maintain production. The container, and increasingly its digitally enabled infrastructure, dramatically reduced this risk.

As a result supply chains have become increasingly global, initiatives such as 'just in time' are common and companies can now decide where manufacturing should take place based on their value drivers (for many this is simply lowest cost, taking into account labour rates and availability, capability, taxes, subsidies, energy costs, and import tariffs).

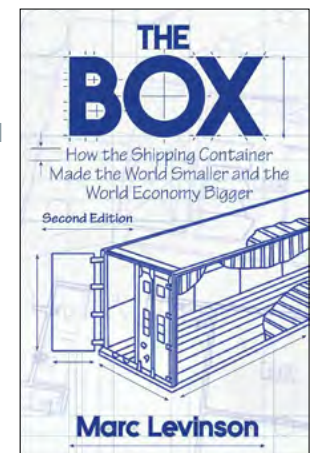

The world's most successful product is an open platform

The iPhone is by some margin the best selling product (including phone, music player, camera and computer) of all time with over 1 billion sales. To put this into context, the all time best selling*:

- Car is the Toyota Corolla with 43 million sales;
- Toy is the Rubik's Cube with 350 million sales;
- Book series is Harry Potter with 450 million sales.

However, the initial sales of the iPhone when it was released in June 2007 were in fact relatively low. The graphs on the right show (bottom) global iPhone sales since initial launch and (top) the sales figures for the first six quarters in more detail.

The original intention was that no third-party developers would be allowed to build native applications for the iOS. This decision was extremely unpopular with both software developers and indeed consumers (who believed the phone was too expensive for the functionality it offered) which led to the disappointing initial sales.

Eventually internal and public pressure plus increasingly common 'jailbreaking' of iPhones by hackers led to Apple reversing this decision. In March 2008 Apple released its Software Development Kit, and in July 2008 it opened the App Store.

The impact was dramatic, and immediate. It can be seen on the graph that sales in the third quarter of 2008 were 720,000 units. In the quarter that immediately followed the launch of the App Store, sales increased nearly ten fold to 6.89 million.

It is worth stressing that Apple did not anticipate what is now by far the most common and powerful use of the iPhone - as an external platform.

However, the App Store has since generated an estimated \$122 billion, with Apple paying out 30% of revenue to third party iOS developers. In 2017 alone payments to developers amounted to \$26.5 billion - this is more than the revenue of the McDonald's corporation. It is likely that App Store revenues this year will exceed the film industry's global box office receipts.†

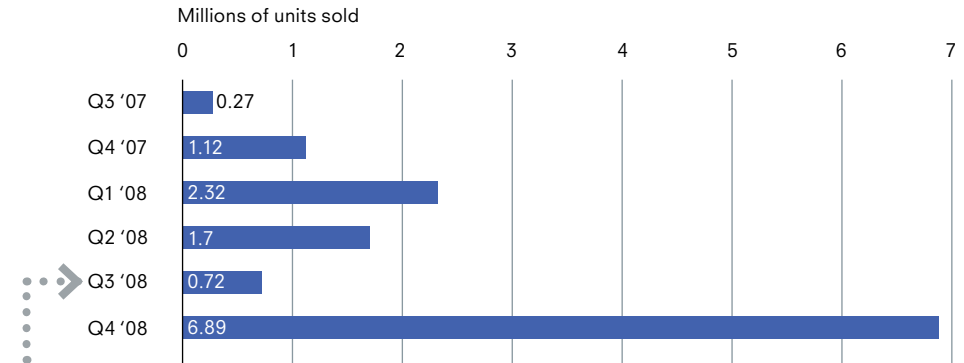

App Store opened 10 July 2008

Global iPhone sales.
Source: Apple, Inc.

Initial six quarters shown
in more detail above

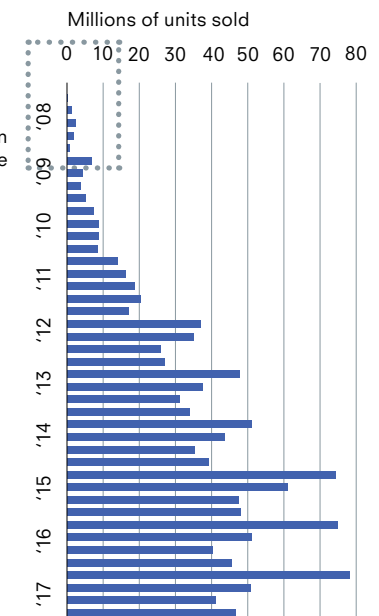

* <http://www.asymco.com/2016/07/28/most-popular-product-of-all-time/>
† <http://www.asymco.com/2018/01/08/the-ios-economy-updated/>

cont'd

What can we learn from these case studies?

These case studies are included as examples of the enormous power of external platforms, but also the unforeseen, consequential benefits that can arise from them.

They demonstrate how new business models, services and even infrastructures can be created that are beyond anything the originators of the platform envisaged.

The invention of the shipping container has transformed the global economy and fundamentally altered the nature of supply chains. The adoption of this platform gave rise to a vast physical and digital infrastructure that maximised its value; it is interesting to speculate what the equivalent would look like for a platform-based construction industry.

Meanwhile, there is an interesting coda to the globalisation aspect of the shipping container story; while for many years there was a shift in manufacturing towards Asia, there are some initial signs that the trend is reversing.

For instance, China's population is aging rapidly (by some estimates the number of retirees could be as high as 44% by 2050* and the United Nations estimates that in the same period the working-age population will reduce by 212 million.***) while factory wages are rising due to an increasingly populous 'middle class'.

This is at a time when the cost of automation is falling and, crucially, is relatively comparable anywhere in the world.

As a result there are signs that companies are 're-shoring' manufacturing capability. This is supported by a report published by EEF (the Engineering Employer's Federation) entitled 'Backing Britain: A Manufacturing Base for the Future'[†] which states that there is a trend of 'production that was previously done in low-cost economies moving back to or closer to UK markets.'

The large scale adoption of platforms and SAWs could certainly be used to help invigorate the UK manufacturing sector. It is not difficult to draw parallels between the 'factory sharing' concept outlined here and the Heathrow Expansion Programme's planned logistics hubs, which will distribute across the country the economic benefits of investment in a major piece

of infrastructure in the south east. These hubs would be ideally placed to harness the network effects of platforms and shared manufacturing capability.

Looking to digital platforms, the success of the App Store and its subsequent emulation by Android and others resulted in the App Economy, which has given rise to Uber, Spotify, Snapchat, Instagram and others. Industry estimates suggest that the App Economy will grow to \$6.3 trillion by 2021, with an estimated user base of 6.3 billion.‡

Again, it is interesting to speculate what sort of apps for design, procurement, employment and logistics might emerge in a platform-based construction sector.

Platforms would almost certainly accelerate the digitalisation of the industry, as well as making it more attractive to the digital-native 'Minecraft generation' that might otherwise eschew construction.

Hopefully these are the sort of debates that this document will prompt. As was set out in the introduction, this was not intended to describe a long term future state of the industry. However, one thing is clear; dramatic change is now required, if not already underway, and there is an opportunity now to start to define the sort of future that the industry, and therefore the economy, could face.

The next section considers how these ideas might manifest themselves in new business models in the construction sector.

* <https://www.forbes.com/sites/kenrapoza/2017/02/21/chinas-aging-population-becoming-more-of-a-problem/#34d05140140f>

** <https://www.wsj.com/articles/as-chinas-workforce-dwindles-the-world-scrambles-for-alternatives-1448293942>

† <https://www.eef.org.uk/resources-and-knowledge/research-and-intelligence/industry-reports/backing-britain-a-manufacturing-base-for-the-future>

‡ <https://techcrunch.com/2017/06/27/app-economy-to-grow-to-6-3-trillion-in-2021-user-base-to-nearly-double-to-6-3-billion/>

New business + commercial models



Introduction

It is intended that the creation of an external platform-based approach will facilitate the adoption of a number of nascent technologies that are proven in other industries but could transform the construction industry.

This section will look at how this has been achieved elsewhere, and what it could mean for the adoption of platforms.

Harnessing the power of a revolution

The power law distribution curve (seen on the right) occurs in many natural phenomena (including numbers of visitors to websites and frequency of words occurring in most languages). On the left hand side a small number of websites (e.g. Google, Facebook) have vast numbers of visitors. On the right hand side many thousands of websites have a small number of visitors. This graph is used to explain the 80/20 rule (the Pareto principle) that '80% of the effects come from 20% of the causes'

Engaging the long tail is one of the critical ways by which Google has been so successful.

The vast majority of Google's revenue is generated by AdWords and AdSense, services which matches search terms to advertisers, placing adverts on screen which are pertinent to the terms that a user is searching. When a user clicks on the advert, the advertiser makes a payment which is split between the hosting website and Google. Around 90% of Google's revenue now comes from advertising; AdWords generated \$89.5 billion of Google's revenues in 2016.

Traditional advertising sits on the left of the graph; a few companies have huge advertising budgets that reach millions of not billions of people, tapering off to the millions of SMEs and individuals with tiny budgets whose adverts are seen by smaller, local markets. AdSense engages the long tail by matching esoteric websites (blogs and niche interest sites) with advertisers of products or services relating to these niche interests.

In this way, bloggers on these subjects make enough money to fund their websites and advertisers of highly specialised products reach a highly targeted, but global, audience.

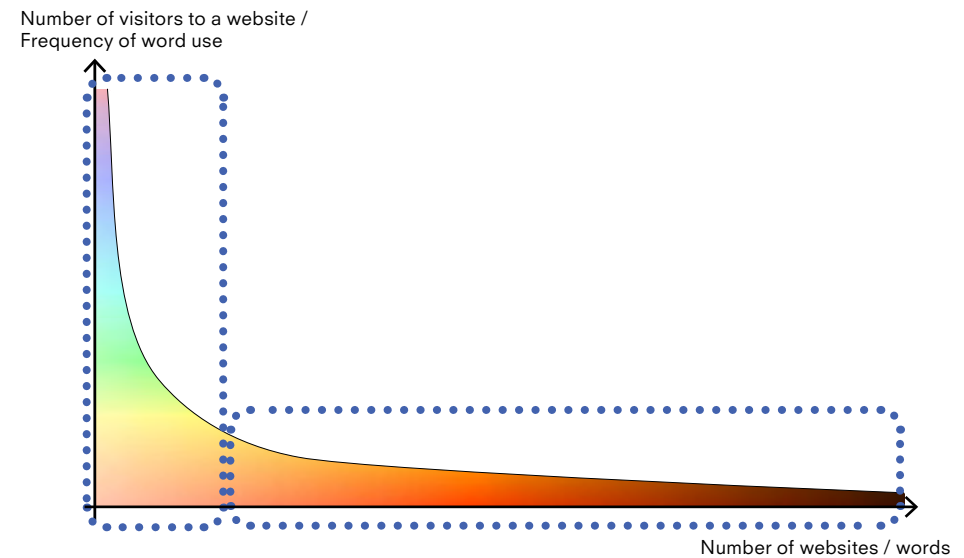

How to harness the power of a revolution

Why is this relevant to Platforms?

Traditional approaches to innovative construction would sit in the left hand side of the power law curve, where large investment in R+D occurred in major projects or with the larger designer or constructor organisations. Smaller projects and SMEs are unable to gain the benefits (and as previously mentioned, learning on these large projects often dissipates once the project is complete).

Making platforms open source would engage the full reach of the industry, giving designers and suppliers on even the smallest projects access to the same best in class innovation and supply chains that are used for high profile major infrastructure.

The enabler would be a digital marketplace which would allow everyone from the smallest to the largest organisations to create a highly effective supply chain network.

Projects could procure platform components and labour as locally as possible by identifying the nearest available SAWs and matching them with competent labour (refer to the section on 'SAWs as a unit of manufacturing currency'). Similarly, projects such as Heathrow could choose to spread their supply chain across the U.K. to facilitate an even spread of investment regionally.

This would also require a new level of logistical control (this is an area where e.g. Amazon excels). The tools required have been established in e.g. the global freight industry (see the earlier case study on the shipping container).

Adopting a platform-based approach would again facilitate bringing learning from other sectors into construction to accelerate the pace of change.

How to harness the power of a revolution cont'd

A similar approach to external platforms here would allow a very wide engagement of the industry, with participation from SMEs who sit within 'the long tail'. A digitally enabled platform-based approach could create a digital ecosystem that would:

- Aggregate existing knowledge;
- Develop communications protocols;
- Encourage an 'iPhone Apps' mentality;
- Publish open source components;
- Incorporate standard elements (e.g. generic floor cassettes);
- Establish formal quality assurance processes to allow components to be validated and added;
- Engage key organisations (clients, manufacturers, contractors);
- Formalise Uniclass categorisation for elements to act as a 'site map' to ease finding and adding components;
- Use COBie / IFC files to build on existing adoption of BIM;
- Encourage software manufacturers to ensure software integrates seamlessly without loss of fidelity;
- Lower reliance on 'translators' such as Bryden Wood and / or allow them to amplify the offer.

This approach would facilitate a range of new initiatives including:

- Factory + workforce sharing;
- Machine learning for component configuration;
- Feedback loops via sensors (continual improvement through IoT);
- Digital object identifiers for long term circular economy;
- Use of blockchain for smart contracts.

A new collaborative model allowing work from all parts of the sector to be made available to everyone, massively accelerating the speed of innovation and adoption

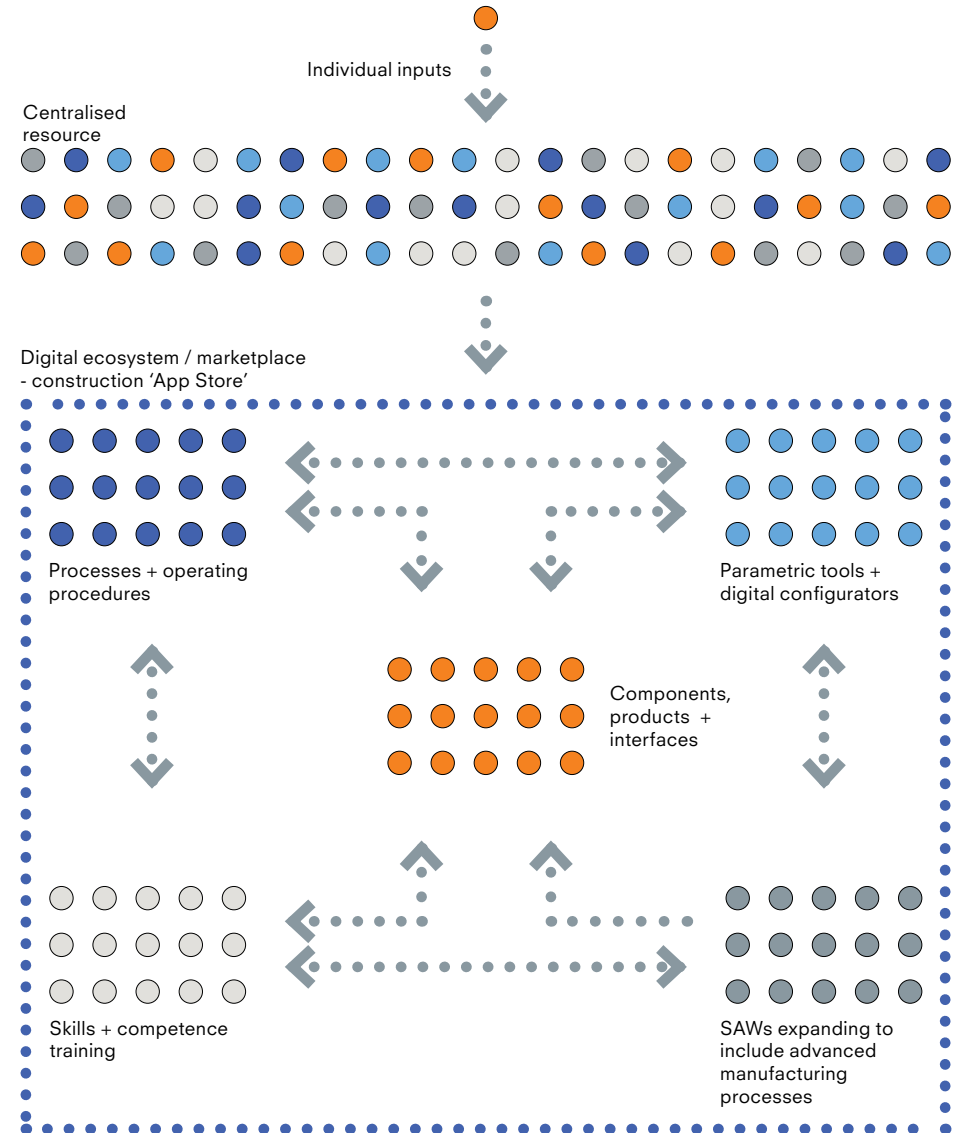

Factory + workforce sharing

One of the most frequent questions regarding the widespread adoption of a manufacturing-led approach relate to the capability and capacity of the 'off site' market.

To date, there are a limited number of suppliers, each producing their own system and only able to service a relatively small share of the market. As a result the uptake of more advanced construction has been hampered by some key blockers or barriers to entry:

- Few suitable systems are readily available, and those that are may often be unsuitable or limited project specific design;
- High barriers to participation - the cost and risk associated with creating a product and taking it to market are high;
- Investment in R&D is lower in construction than in other sectors;
- Design professionals may not have the requisite skills or inclination to adapt to manufacture-led solutions.

Meanwhile, the key issues from the supply side i.e. those owning and operating factories, include:

- Output spikes dramatically with number of orders;
- Planning resources, materials and cash flow is very difficult;
- As a result, few people can afford large risk and expenditure involved in setting up a factory which may rarely run at full production;
- Few people have the skills to drive full DfMA solutions;
- The need for mass customisation exacerbates this, encouraging factory owners to specialise in one particular product or system.

This is represented by the graph on the right - it is very difficult to keep a single facility at a consistent level of productivity. In between busy periods fulfilling a particular order there may be significant down time. The overhead cost of this down time must somehow be recovered, and is often amortised against orders placed. As a result, the customer does not realise the maximum cost benefit of an industrialised approach.

The adoption of a platform-based approach would cut across

many of these issues and significantly lower the barriers to entry. For instance, open sourcing the components would remove the time, cost and skills needed to design the platforms from first principles; clients and designers could adopt them immediately.

Meanwhile there are many underutilised factories that have the elements necessary for the delivery of off-site manufactured systems or components, but not the throughput to keep the facility operating at maximum capacity.

The use of external platforms, shared components and a well established market for SAWs would create a much more consistent pipeline of demand by aggregating the needs of multiple programmes, which can then be spread across a number of facilities working at a steady state of output (see graphs on the following pages). SAWs would allow activities to be moved to the most appropriate place in the supply chain, with factories as places where multiple SAWs could be brought together in a temporary or permanent state.

Over time, this could result in:

- Multi-purpose factories used to deliver a number of systems for different clients;
- Lower barriers to entry into factory based construction - reduce costs by maintaining productivity levels, sharing overhead etc.;
- The ability to set up factories as temporary nodes in the supply chain.



Factory + workforce sharing cont'd

Sharing capacity across a network of permanent and temporary facilities, minimising 'down time' and / or unused space (the cost of which is otherwise paid for as part of the factory overhead) would facilitate a number of possible scenarios:

- Providing manufacturing space for start up companies wishing to enter the offsite market. Underutilised areas could be sectioned off and rented to people thus saving them the cost of buying, building and developing a new location. It could test the viability of the product without high capital cost;
- Enabling existing products to be delivered from a range of participating facilities, allowing small operations to upscale their offer or products to be manufactured closer to their point of deployment (with reduced transport time and cost);
- Enabling participating facilities to combine and trade capacity to drive down the cost of off-site solutions and move this further into the mainstream of construction delivery.

There are a number of benefits that such an approach could provide:

- Reduced cost of both new and existing systems by offsetting some of the overhead cost;
- A central point of contact for clients or contractors who might otherwise not consider a platform-based solution or not know where to procure one;
- Subject to issues relating to IP, a potential means of improving collaboration within the off-site sector, with benefits for all (manufacturers, clients and end users);
- By lowering the barriers to participation in the off-site market, a number of platforms might be developed which would otherwise be seen as too marginal.

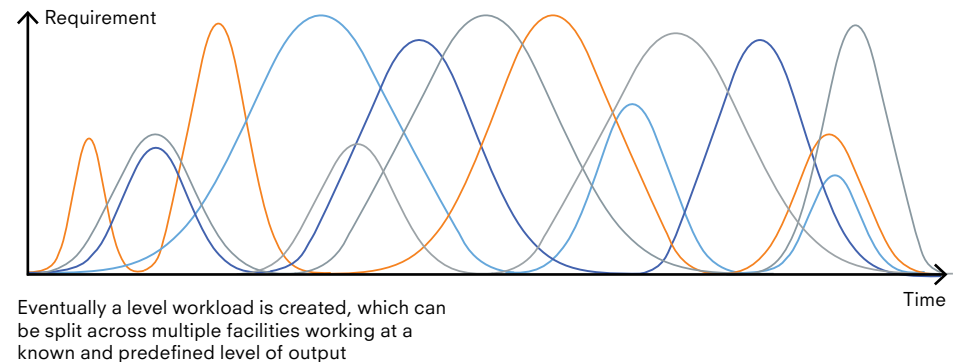
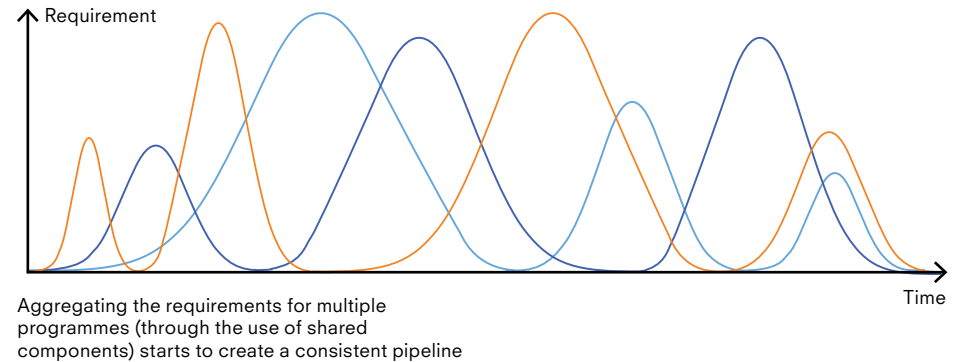

Adoption of new tools + processes

* Nicole Pehan, 'Designing with Machine Learning', WeWork blog 11 September 2016.

Platforms are highly digitally enabled, with data rich parametric digital components generating high quality information for design, procurement, logistics, installation and operation.

This will facilitate the use of new and more efficient processes in each of these areas. Some technologies whose adoption would be accelerated by use of platforms are considered below.

Use of automation, generative design, machine learning + AI

The use of automation in design is already having a significant impact on the design of assets and infrastructure. Highways England's 'Rapid Engineering Models' automate the placement of standard components (gantries, signage etc.) for their Smart Motorways programme, reducing design time by an order of magnitude. Meanwhile WeWork have developed a neural network that predicts meeting room utilisation ~40% more accurately than human designers*. This is a specific use case but it is likely that this sort of technology will increasingly be used in the design of high performing assets, networks and systems.

Platforms would perfectly lend themselves to this approach - the outcome from one project could be used to drive a more efficient use of the components in subsequent projects to create assets that sit increasingly to the top right of the efficiency vs. effectiveness graph.

This would also increase the benefit of sensors in 'smart' assets - currently these capture data about the performance of very specific assets. If, however, the data could be used to inform the next generation of platform components and their optimum configuration this would enhance the learning and feedback loop.

If digital workflows largely eliminate repetitive tasks, design professionals can spend more time understanding the functional outcomes for new assets, spending more time on value adding activity and looking at a wider range of design forms and concepts or putting more design value on more things.

This would provide a more even distribution of quality of design, and allow designers to keep pace with the estimated

£600 billion investment in UK infrastructure in the next decade (and global population growth, increasing urbanisation etc.)

Object identifiers

Use of RFID tags, QR codes and data matrices on physical components for tracking and installation is increasingly common (refer to the 'Advanced Construction Training' section of 'Delivery Platforms for Government Platforms').

This could be enhanced by the use of Digital Object Identifiers (persistent identifiers that allow the data on a particular component to be accessed through the project lifecycle) or similar. This would strengthen the 'digital to physical' link and create another way of interrogating components, particularly at end of life or for re-purposing assets.

New procurement + payment processes

Earlier in this section the concept of a digital marketplace for construction was referenced, matching project demands to capacity and capability in terms of labour and manufacture.

The use of identifiers to track components through manufacture, assembly and operation would support this by facilitating new payment methods linked to e.g. components leaving the assembly factory or being installed.

Circular economy

Standardised components (with easy access to their whole life performance data) could easily be re-purposed or reconfigured at end of life or as an asset's needs evolve.

The ability to feed components back into a circular economy may provide more creative freedom for design. If architects didn't have to build everything with a 60 year life span, if the building was likely to be re-purposed in 20 years, this gives unprecedented freedom in design, and a much greater level of flexibility within the urban landscape.

Appendix

Further reading



Past examples of industry analysis

Periodically, the UK construction industry is subject to a detailed review that seeks to define the key barriers to improvement, and sets out some recommendations.

Most recently, the Farmer Review of the UK Construction Labour model published in October 2016 identified some 'Critical symptoms of failure and poor performance' in the industry:

- Low productivity;
- Low predictability;
- A lack of collaboration and improvement culture;
- A lack of R&D and investment in innovation.

Past studies considering the industry include:

- Constructing the Team (often referred to as the The Latham Report) published in 1994;
- Rethinking Construction (often called The Egan Report) published in 1998.

A summary of the recommendations made by these two reports are included on the following pages - it is worth noting that many of the topics that have been discussed in this document are closely related to these recommendations.

The Egan report was published in the same year that Google was founded. Considering the impact that Google and its subsidiaries (notably YouTube, Android, Nest Labs) have had since 1998, and comparing it with changes in the construction sector in the same time-frame highlights the pace of change that is possible in other sectors.

Perhaps now the conditions are right to finally see the industry make a step change in terms of productivity and innovation, with platforms providing a significant shift towards achieving this goal.

Past examples of industry analysis cont'd

- Implementation begins with clients - Clients, and especially Government, continue to have a role in promoting excellence in design;
- Government should commit itself to being a best practice client;
- Private clients have a leading role and should come together in a Construction Clients' Forum;
- Tenders should be evaluated by clients on quality as well as price;
- A productivity target of 30% real cost reduction by the year 2000 should be launched;
- There is scope for improvements through greater standardisation of components and design details and more off-site prefabrication. This will require effective teamwork by designers, contractors, subcontractors and manufacturers.

Five key drivers of change which need to set the agenda for the construction industry at large:

- Committed leadership;
- A focus on the customer;
- Integrated processes and teams;
- A quality driven agenda;
- Commitment to people.

To achieve these targets the industry will need to make radical changes to the processes through which it delivers its projects. These processes should be explicit and transparent to the industry and its clients. The industry should create an integrated project process around the four key elements of:

- Product development;
- Project implementation,
- Partnering the supply chain;
- Production of components.

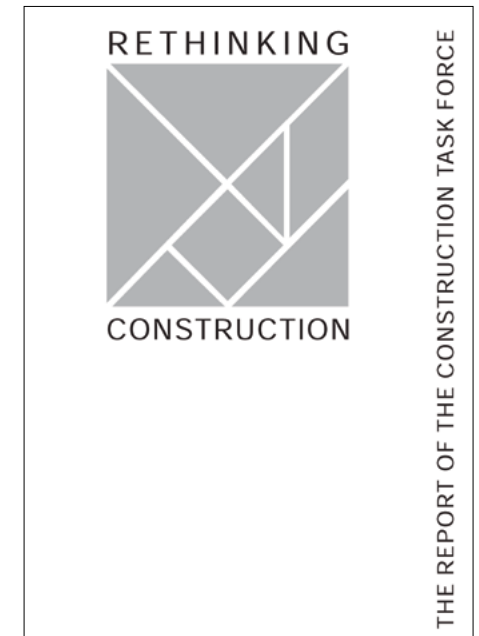
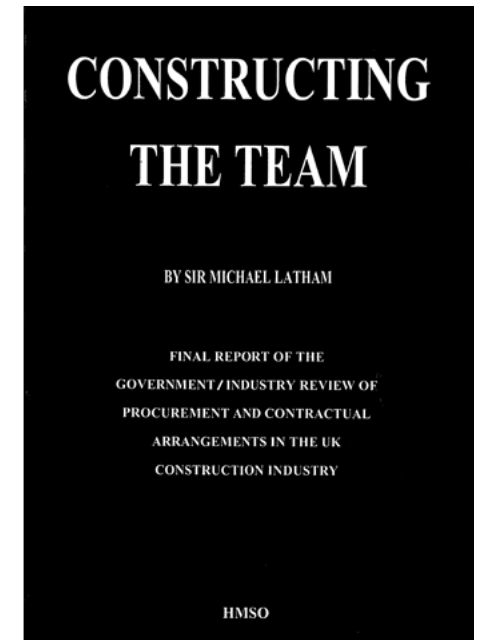

Recent Government publications

- To improve the productivity of construction, the Transforming Infrastructure Performance programme will use the power of government spending to help drive the adoption of modern methods of construction;
- This will build on the commitment made by five government departments to adopt a presumption in favour of offsite construction by 2019 across suitable capital programmes where this represents best value for money;
- This will bring together government and industry to facilitate implementation of the Construction Sector Deal, including £170m of investment through the Industrial Strategy programme, Transforming Construction, which will support innovation and skills in the sector.

1. Judge strategic choice and trade-offs;
2. Improve the way we set up our projects;
3. Create a transport infrastructure performance benchmarking forum;
4. Establish a common approach;
5. Promote long term, collaborative relationships;
6. Challenge standards;
7. Exploit digital technologies and standardise our assets.

cont'd



Recent Government publications cont'd

1. Prioritising investment in the right projects;
2. Improving productivity in delivery;
3. Maximising the overall benefits of infrastructure investment;

To achieve this, the IPA prioritises the following four activities:

- Setting up projects for success;
- Creating market confidence;
- Building delivery capability in government;
- Measuring and improving performance.

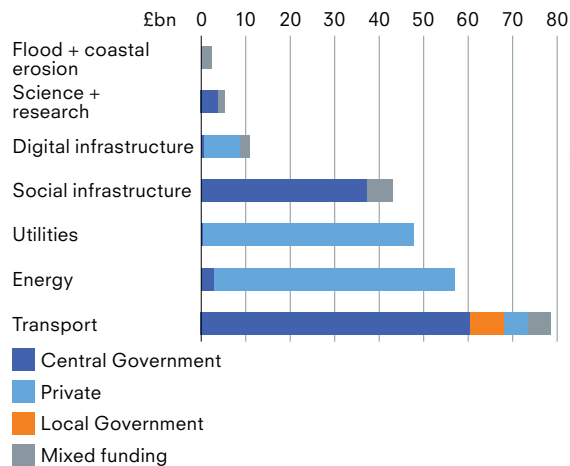
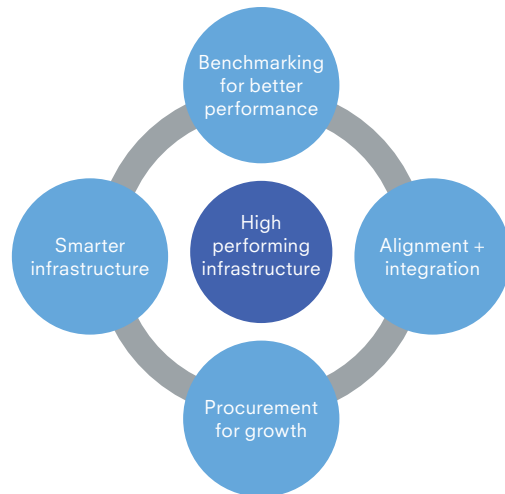

142

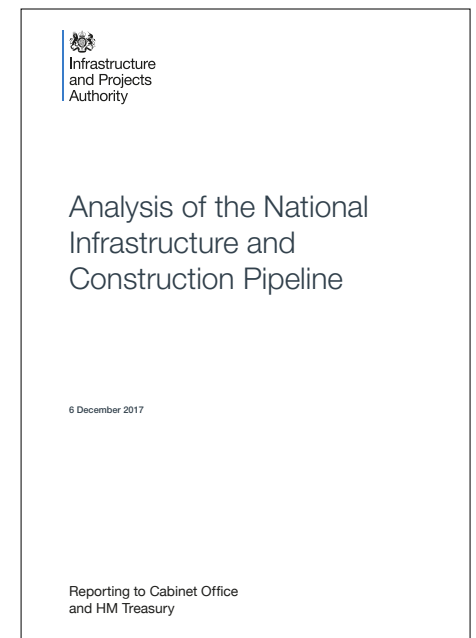
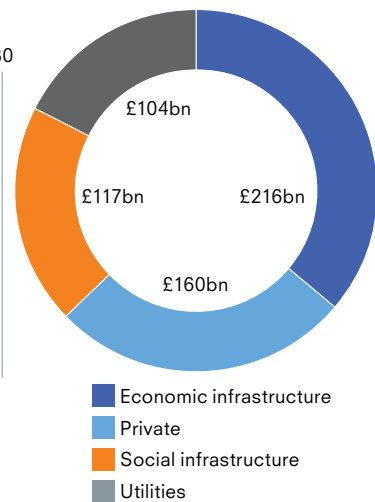

143

Digital Built Britain publications

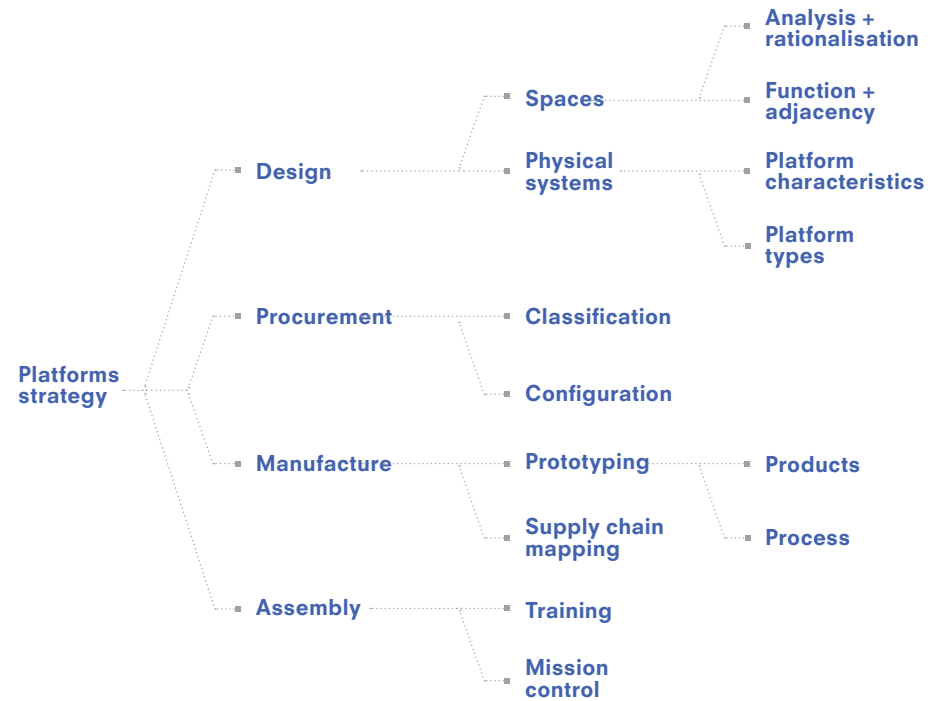

This provides further detail on digitally-enabled workflows through every stage of a project life cycle from data analysis in the briefing stage, rapid generation of design, to sharing data for optimised procurement, logistics and assembly.

- Data analysis + visualisation;
- Parametric components;
- Rapid engineering models;
- Collaborative working;
- Data-driven delivery controls.

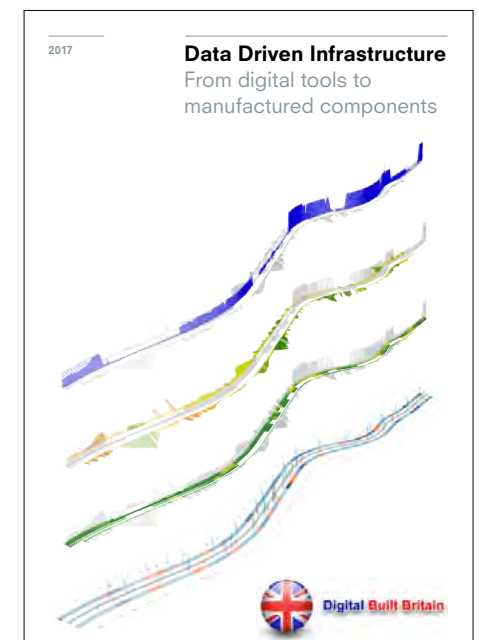

Tel. +44 (0)20-7253-4772
Email info@brydenwood.co.uk
brydenwood.co.uk

Bryden Wood
100 Gray's Inn Road, London
WC1X 8AL, United Kingdom

